



Self-Regulating Heating Cables - OSR Series

Design Guide



TABLE OF CONTENTS

INTRODUCTION

A reliable partner.....	4
The technology	4
Key benefits.....	4
Configuration.....	4

ROOF AND GUTTER DE-ICING SYSTEM

The challenge	6
The solution.....	6
Safety guidelines	6
Cable selection	7
Cable description	7
Product configuration options.....	7
Recommended cable type and output	7
Key design notes	9
Design steps for roof and gutter heating	10
1. Location and area, determining requirements	10
2. Calculating heating cable length	12
3. Heating cable selection	17
4. Additional heat tracing requirements for flat roof drains	18
5. Control systems for roof and gutter applications.....	19

PIPE TRACING FOR FREEZE PROTECTION AND TEMPERATURE MAINTENANCE

The requirement.....	22
The solution.....	22
Selecting the proper cable.....	23
Product description and application information.....	23
Product configuration options.....	23
Ratings and approvals	23
Ordering information.....	24
Self-regulating heating cables for pipe applications	25
Key design notes, basis for a good design	25
Calculating heat loss for freeze protection applications in pipelines	26
Step 1: Determine heating cable requirement	27
Step 2: Calculate heating cable requirements for heat sinks, connections and terminations.....	28
Step 3: Determine required heating cable circuits	29
Step 4: Choose installation accessories	30
Project notes/tips.....	31
Control systems for pipe freeze protection applications.....	33

DATA SHEETS, OPTIONS, ACCESSORIES AND DESIGN FORMS

CABLE DATA SHEETS	36
CORRECTION FACTORS/MULTIPLIERS FOR OPERATION OF HEATING CABLES IN 208V	39
CONTROL OPTIONS	40
INSTALLATION ACCESSORIES AND OPTIONS	43
COMMERCIAL HEAT TRACING DESIGN FORM	45

WARRANTY

Visit our website at ouellet.com.

Ouellet Canada Inc. reserves the right to make any changes to this sheet or its products at any time without notice.

A reliable partner

Eltherm® a German manufacturer and Ouellet Canada have formed a strategic alliance in North America to market the residential, commercial and industrial line of self-regulating heat tracing products manufactured by eltherm®. The Ouellet Canada Group will exclusively offer eltherm®'s superior line of self-regulating (ELSR) heat tracing products through it's extensive network of sales partners throughout Canada and the United States.

The technology

Self-regulating heating cable consists of two parallel, current carrying bus wires embedded within a networked plastic heating element that is doped with surrounding carbon particles (commonly referred to as a semi-conductive matrix). When the temperature increases during operation, the non-conductive elements within the matrix expand at the molecular level, increasing the distance between the conductive carbon particles. The resistance of the heating element increases, leading to a drop in output (power). When it cools down, this process is reversed and output increases.

The physical property and characteristics of a self-regulating (self-limiting) heating element provide several benefits, including the ability to overlap the self-regulating cable at various points of the installation, and, for many applications, to eliminate the need for temperature control and/or limiting devices.

Self-regulating heating cables are perfectly suited and commonly used for freeze protection as well as low, medium and medium/high temperature applications, and provide a flexible, economical means to prevent heat loss and temperature maintenance service.

Key benefits

- Self-regulating with adaptable output anywhere along the heating circuit
- Various temperature range possibilities and applications
- Long life-cycle
- No temperature regulation or limiting required
- Easy to assemble and handle
- Cut-to-length, off the spool or at any point
- High chemical resistance available (fluoropolymere)

Configuration

Eltherm®'s proprietary self-regulating heating element (matrix) design ensures that the heating element provides reliable and long-lasting output throughout the life of the cable. Only the highest quality materials coupled with modern manufacturing techniques ensure the safest and most effective operation. A wide selection of power output ratings and voltages is also available to cover any possible application.

Eltherm®'s ELSR heating cables are available in various configurations, including a unique aluminum foil shield (AO) with embedded ground wires designed exclusively for a rapid power and end termination assembly in the field for use in residential, commercial and industrial service. A tinned copper classic braid design and various outer jacket configurations are available to protect the cables from corrosive agents or other harsh environments.

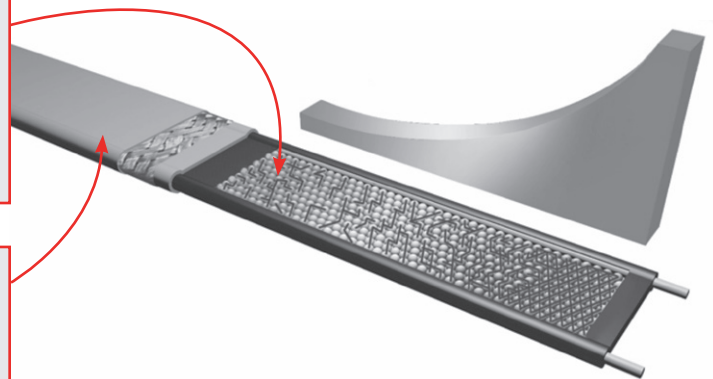



Roof and gutter
de-icing system



ROOF AND GUTTER DE-ICING SYSTEM

The challenge

The accumulation of ice and snow can cause severe structural damage to roofs, gutters, downspouts or any exposed external piping or water run-off or distribution systems in commercial and residential buildings. There is an increased danger of accidents caused by falling icicles and shifting snow. The use of suitable de-icing systems using electric heating cables can prevent ice formation and protect against property damage.

As snow collects on the roof, rising heat from the building below or exposure to sun melts the snow, creating flowing water. This water will reach the colder collection systems of the building, where it will eventually refreeze, causing blockages and ultimately damaging the gutters or run-offs. Water that cannot be directed away from a property may get into the internal areas of the building.

The solution

The heat tracing experts at eltherm® have spent years developing and optimizing freeze protection solutions for commercial and residential applications. From a wide selection of the most reliable self-regulating cables to easy to use connection and terminations assemblies and the most cost-effective control and sensing technology, eltherm®'s line of ELSR series self-regulating heat tracing products for commercial and residential roof and gutter systems provide a complete solution for the most challenging installations. This design guide provides a basis for designing roof and gutter snow and ice melting systems.

Safety guidelines

The safety, reliability and performance of heat tracing depend on how the cable is selected, installed and maintained. Incorrect design, handling, installation or maintenance of the cable could result in cable failure, inadequate de-icing, electric shock or fire. To minimize these risks and ensure the systems function properly, please follow manufacturer recommendations and instructions carefully.

Installation must meet the requirements of the following codes:

- Canadian Electrical Code
- National Electrical Code
- Any other applicable local and/or national code

Where required by law, this product must be installed by a qualified individual.

To prevent any possibility of electrical shocks, the power supply must be turned off before handling the heating cables.

Self-regulating heat tracing cables must be installed with a ground fault circuit interrupter (GFCI), in compliance with the Canadian Electrical Code and the National Electrical Code.

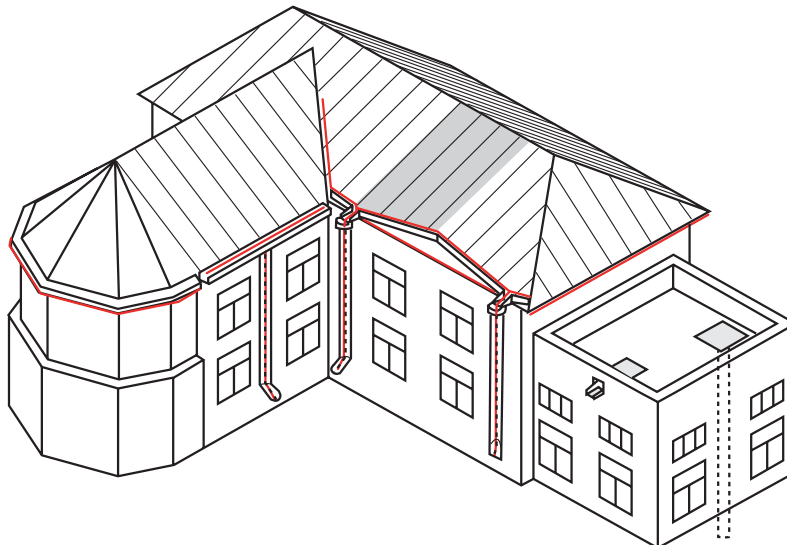

Cable selection

Use Eltherm® ELSR-NA Series self-regulating heat tracing products for roof and gutter applications.

Cable description

Eltherm®'s ELSR-NA line of self-regulating heat trace cables are designed for freeze protection, low temperature maintain, and to provide snow and ice melting for commercial and residential roof and gutters applications. All NA series heating cable types are approved for use in non-hazardous (ordinary) and hazardous locations as well as outdoor installations (Wet rated and UV resistant).

Product configuration options

Type AO

A unique, easy-to-terminate, light weight cable designed exclusively for low and medium temperature applications and constructed to save installation time and costs. The AO cable design features an aluminium foil shield and thermoplastic outer jacket.



Type BO

The classic self-regulating heating cable design features a protective tin-plated copper braid and a thermoplastic outer jacket.



Cable heat output depending on the environment

In Snow and Ice (120V cable):	11W/ft. @ 50 °F (36W/m @ 10 °C)
In Dry Air:	7W/ft. @ 50 °F (23W/m @ 10 °C)
In Snow and Ice (240/208V cable):	13W/ft. @ 50 °F (42W/m @ 10 °C)
In Dry Air:	8W/ft. @ 50 °F (26W/m @ 10 °C)
Available Supply Voltages:	120V or 240/208V
Minimum Installation Temperature:	- 30 °C (- 22 °F)
Minimum Bend Radius:	1 in. (25 mm)
Maximum Circuit Length (120V):	180 ft. (40A @ -22 °F)
Maximum Circuit Length (240V):	280 ft. (40A @ -22 °F)
Certification:	CSA C22.2.130.03; -WS CAN/CSA 60079-7:12, 60079-0-11 ANSI/IEEE 515, 515



ROOF AND GUTTER DE-ICING SYSTEM

The eltherm® self-regulating heat tracing system for roof and gutter applications commonly includes the components outlined in the table below. For detailed specifications and product descriptions of each component please refer to the technical section of INSTALLATION ACCESSORIES AND OPTIONS.

Model Number	Description
ELSR-NA-7-1-AO/BO	7W/ft. @ 120V/41 °F
ELSR-NA-8-2-AO/BO	8W/ft. @ 240V/41 °F
KIT-OSR-ELSR-NA	End and power termination kit with warning sticker NA Series
ELB-RCLIP	Roof clips for cable, qty 25
ELB-20	Downspout mounting plate
ELB-21	Gutter mounting plate
DS-2C	Aerial mounted controller with sensor to detect humidity and temperature, 30A, 100V to 277V

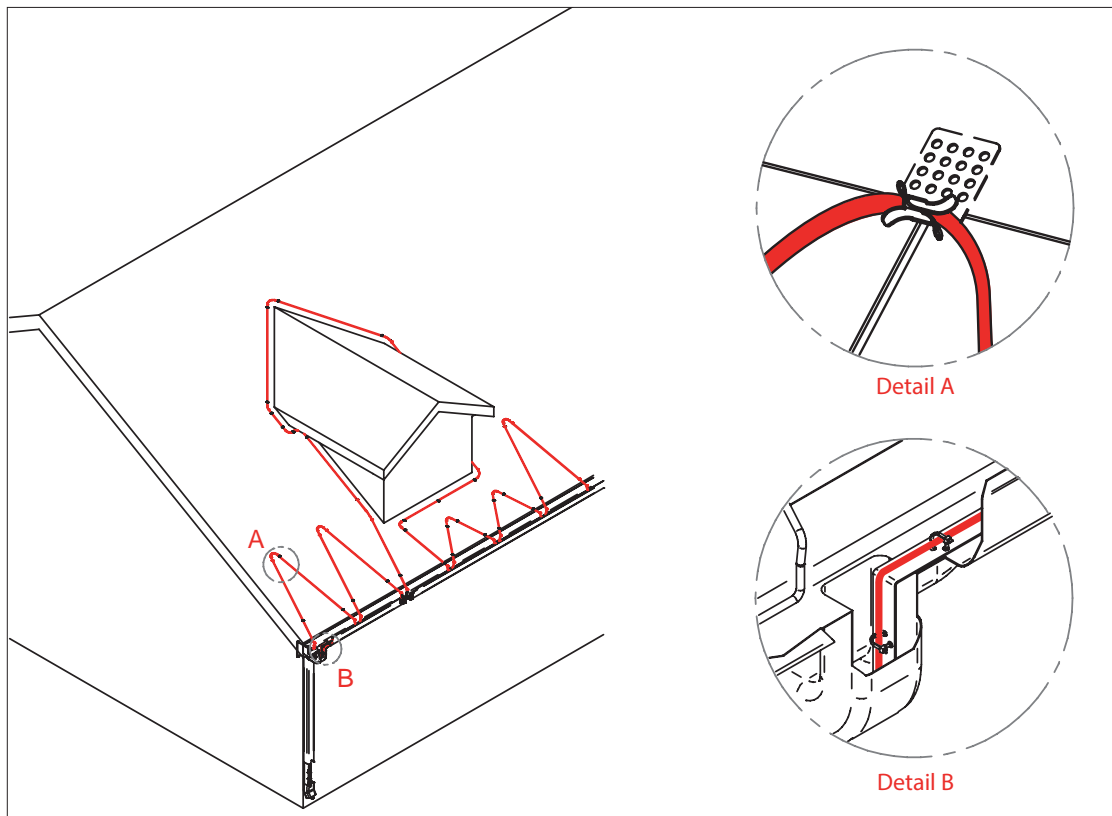

Key design notes

Where to apply heat tracing in roofs and gutters?

Electric heat tracing is applied on commercial and residential roof and gutter systems to provide drain paths for the removal of flowing water and prevention of ice dams on uninsulated roofs, roof overhangs and building run-off systems. Ice dams are formed when warmer sections of the roof melt accumulated snow and ice, creating flowing water. This flowing water will re-freeze and accumulate on the colder roof and gutter sections creating a potential for structural damage to the building.

Typical areas requiring electrical heat tracing include:

- Roof overhangs with gutters and downspouts
- Roof overhangs without gutters and downspouts
- Water path/run-down sections of the roof structure (channels and valleys)
- Gutters and downspouts only
- Flat roof flowing water paths and drains

Self-regulating heating cable are a preferred technology for roof and gutter applications as they are suitable for installations with most materials, including:

- Metal, plastic, wood gutters and downspouts
- Metal, wood, plastic shingle and roof material
- Rubber and tar flat roof design materials

IMPORTANT: We recommend that you always check with the roofing material manufacturer to see if the product can be used with self-regulating heating cables.

Design steps for roof and gutter heating

1. Location and area, determining requirements

A critical first step in the design of a roof and gutter heating system is to carefully inspect and review facility drawings to ensure that all uninsulated surfaces (e.g., overhangs, gutters and downspouts) are incorporated in the design. The systems and calculations provided in this guideline are for normal winter conditions and consider average snowfall accumulations and rates of less than 9 in.



Roof and gutter snow and ice melting cables should be installed during the warmer months of the year. Eltherm® and Ouellet Canada highly recommend the use of appropriate control systems for snow and ice melting applications to ensure the system can be energized prior to significant ice and snow accumulation.

The roof structure determines the installation method and cable layout to be used.

For shingle roofs, self-regulating heating cables should be installed in a serpentine (zig-zag) pattern with tracing widths of approximately 24 in. (610 mm) for normal and moderate snowfall conditions. Where conditions require (e.g., steep roof slopes or longer eave-to-ridge distances) snow fences are recommended to prevent damage to the facility and heating cable installation.

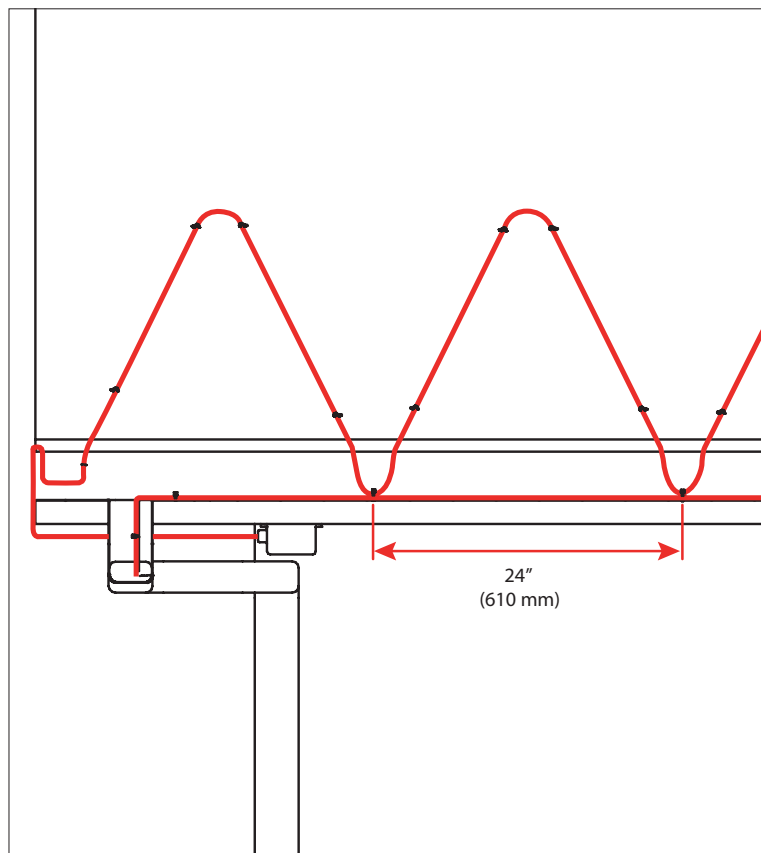

Figure 1: Heating cable installation on shingle roof

For metal, corrugated-tile roofs, the heating cable should be installed parallel to standing seams or along any lengths of the corrugated section. If a zig-zag pattern is preferred for these types of roof structures, additional buckling protection hardware is required to protect the heating cable installation from falling snow and ice.

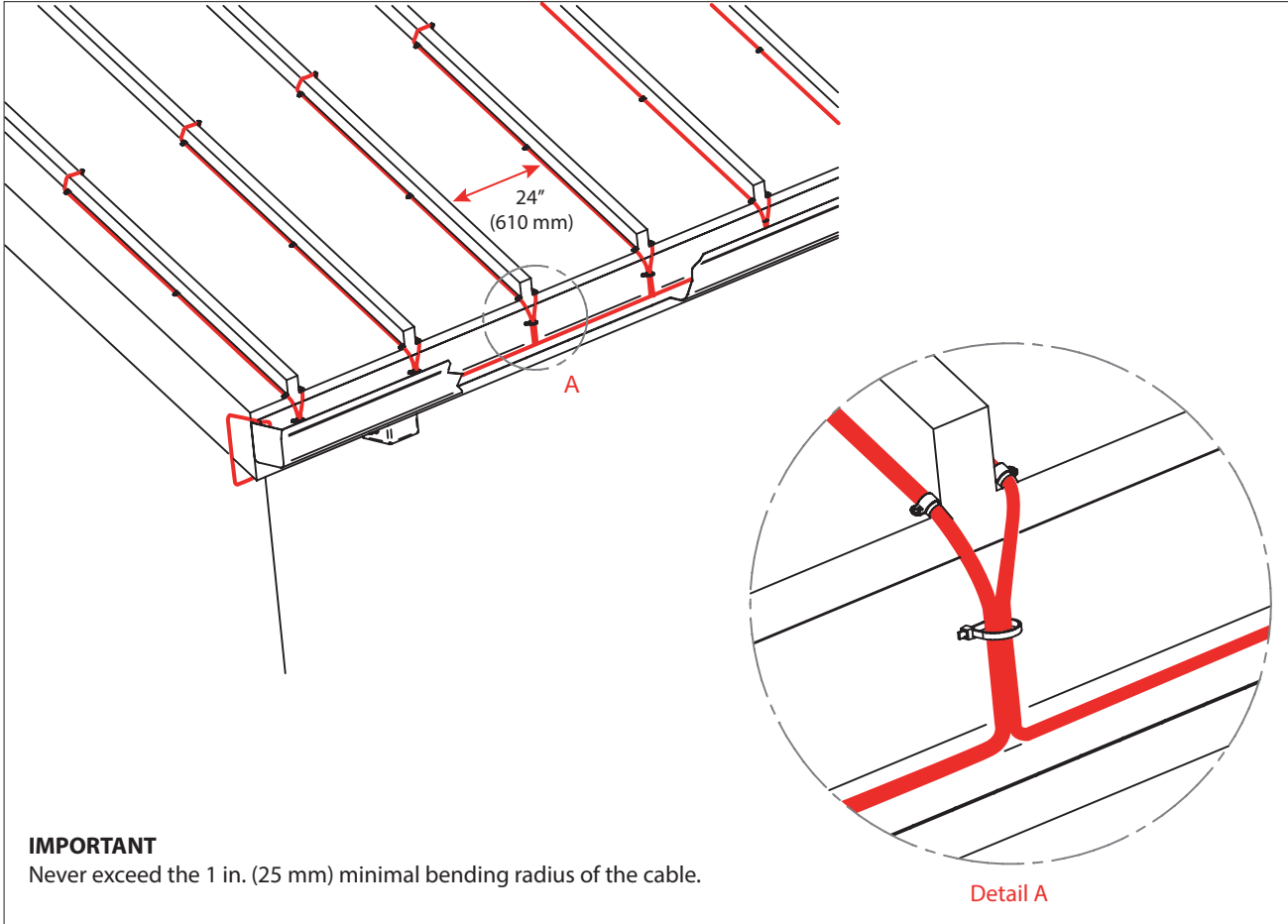

Figure 2: Heating cable installation on metal roof

ROOF AND GUTTER DE-ICING SYSTEM

2. Calculating heating cable length

Table 1 provides a basic heating cable worksheet to assist with calculating the required heating cable lengths for a roof and gutter installation. Step-by-step descriptions of the individual sections and how to calculate the required heating cable are provided in the following pages.

Roof and gutter heating cable calculation worksheet

Section	Calculation	Length
A) Roof edge	Roof line length (ft.) x multiplier (Table 2 or Table 3)	_____ ft.
B) Drain path/drip loops	Roof line length (ft.) x 0.5	_____ ft.
C) Gutters	Total gutter length (ft.) x numbers of heating cable runs (Table 5)	_____ ft.
D) Downspouts	Downspout length (ft.) x 2, plus 1 ft. for end termination	_____ ft.
E) Valleys	Valley length (ft.) x 0.67, x 2	_____ ft.
F) Power connection	Add 3 ft. per power connection	_____ ft.
TOTAL HEATING CABLE REQUIREMENT:		_____ ft.

Table 1: Self-regulating heating cable roof and gutter worksheet

A) Roof edge

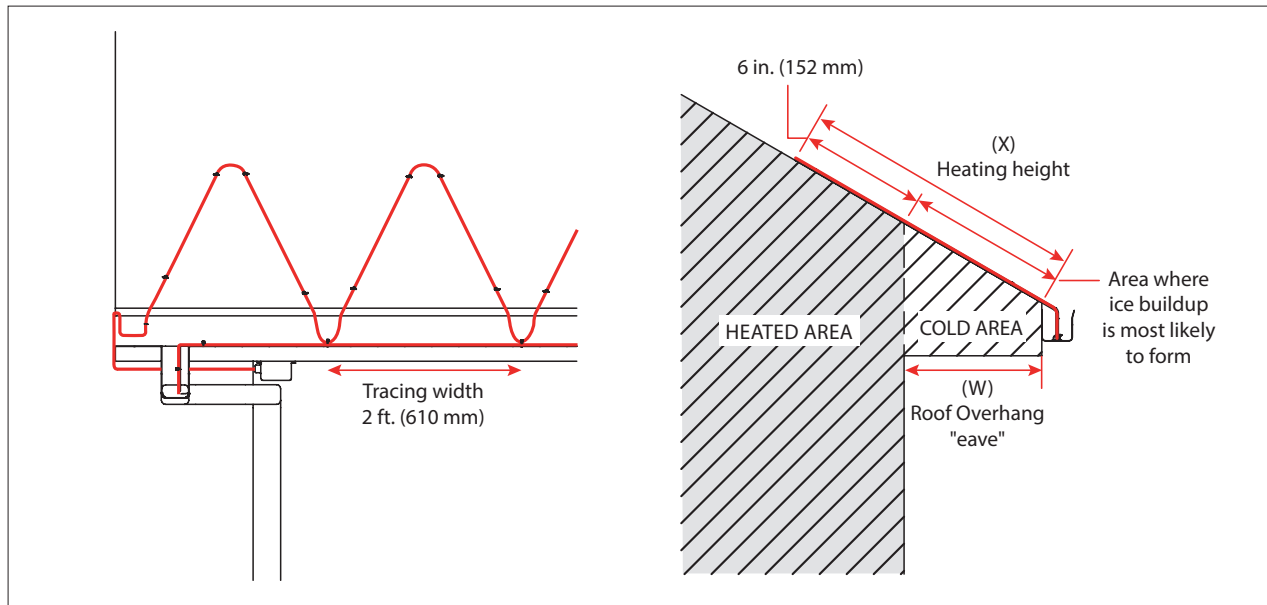

Determine the required length of heating cable to apply to shingle roof overhangs using the following tables.

(W) Roof Overhang "eave"	(X) Heating Height	Multiplier (per ft. of roof edge)
6 in. (152 mm)	12 in. (305 mm)	1.6
12 in. (305 mm)	18 in. (455 mm)	2.0
24 in. (610 mm)	30 in. (760 mm)	3.0
36 in. (915 mm)	42 in. (1065 mm)	4.0

Table 2: Multiplier to use per feet of roof edge

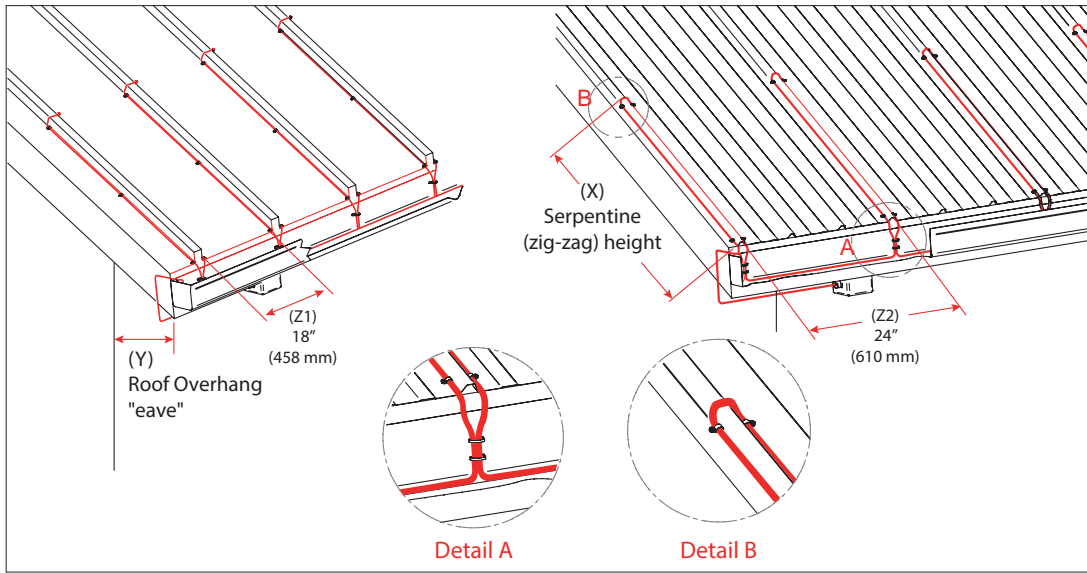

For metal/and corrugated-tile roofs, use the following calculations provided in Table 3 below.

(Y) Roof Overhang "eave"	(X) Serpentine (zig zag) height	Roof Seam Distance per ft. of Roof Edge	
		(Z1) 18 in. (Multip.)	(Z2) 24 in. (Multip.)
6 in. (152 mm)	12 in. (305 mm)	2.8	2.4
12 in. (305 mm)	18 in. (455 mm)	3.5	2.9
24 in. (610 mm)	30 in. (760 mm)	5.0	4.0
36 in. (915 mm)	42 in. (1065 mm)	6.5	5.1

Table 3: Multiplier for steel roofing per feet

B) Drain path, drip loop

Factor additional heat tracing for drain path to extend into the gutter, or extend heating cable loops below roof edge to form drip loop.

Roof length (ft.) x 0.5

Table 4: Multiplier for drip loops

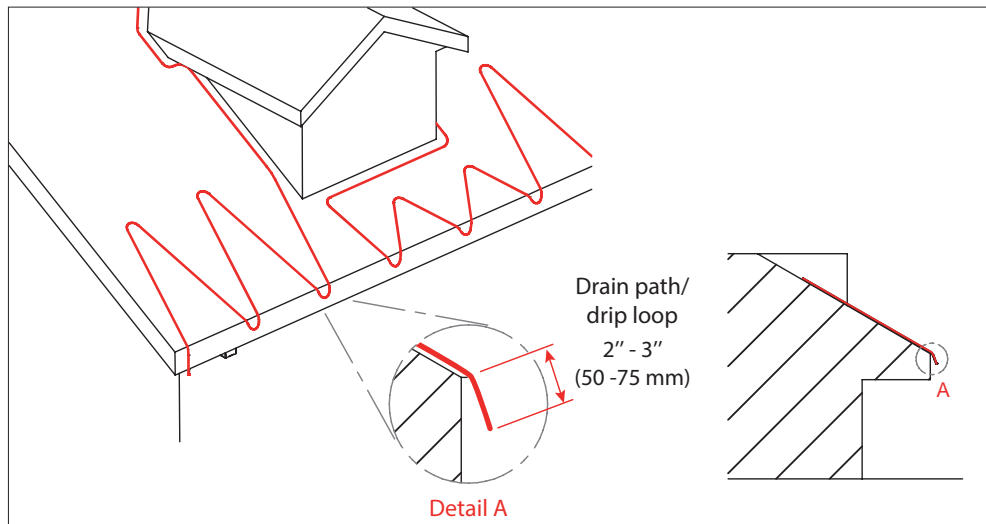

ROOF AND GUTTER DE-ICING SYSTEM

C) Measuring and calculating for gutters

Measure total gutter length along roof and multiply by the numbers of runs required.

Allow a single run of heating cable for gutter widths of less than 6 in. (152 mm), two runs (calculate two gutter lengths) for gutters larger than 6 in. (152 mm).

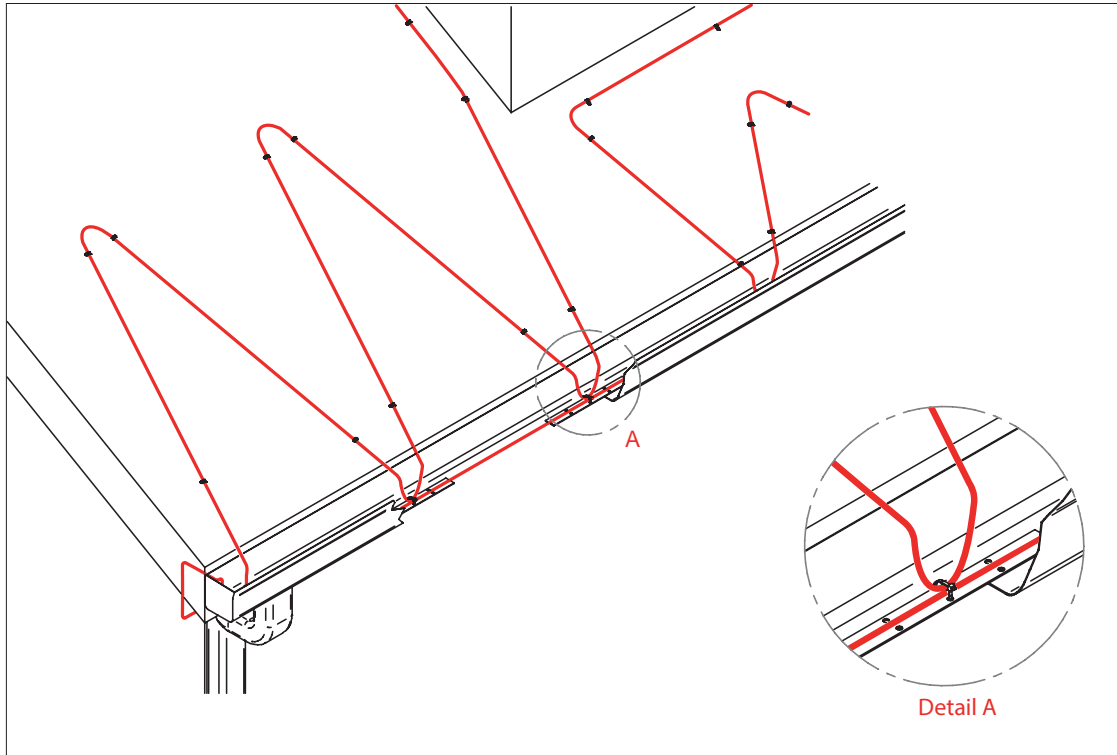

Gutter (width)	Shingle roof Number of heating cable runs	Metal/and corrugated-tile roofs Number of heating cable runs
Up to 6 in. (152 mm)	1	0*
Over 6 in. (152 mm)	2	1

* For metal/and corrugated-tile roofs, the gutter is already taken into consideration in the multiplier figure in Table 3.

Table 5: Gutter length requirements

D) Downspouts

Calculate running the heating cable down the entire length of downspout and back up.

We recommend an additional 12 in. to 18 in. (305 mm to 455 mm) of cable for end termination to be located back-up into downspout.

NOTE!

Installation standards and best practices recommend avoiding the use of in-line splice and tee kits for roof and gutter installations. This requires looping the heating cables in downspouts.

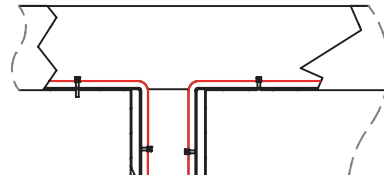

Figure 1: Heating cable at top of downspout

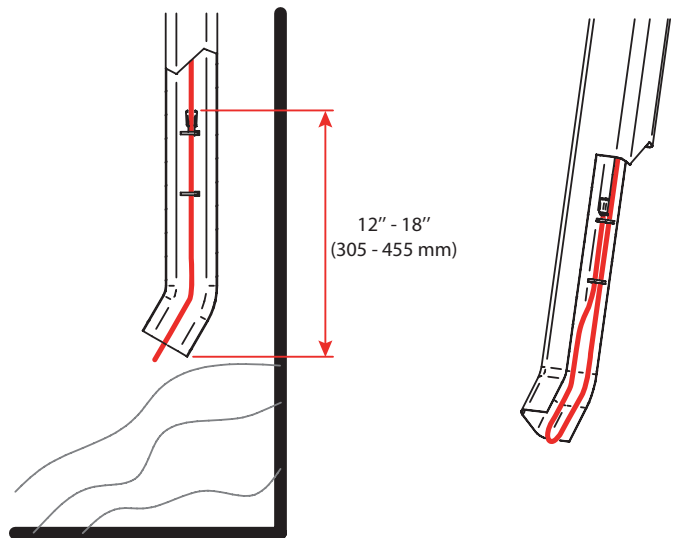

Figure 2: Heating cable installation in downspouts

For downspouts that extend into underground storm sewers, extend the heating cable below the ground to a point near the horizontal drain, as outlined in Figure 3.

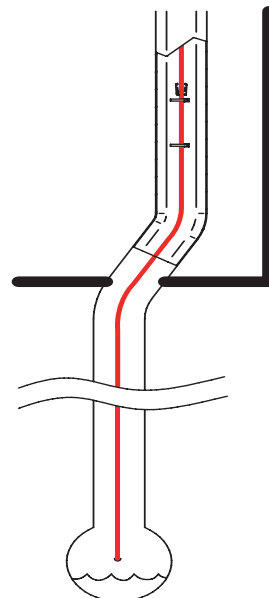

Figure 3: Heating installation below-ground drain system

ROOF AND GUTTER DE-ICING SYSTEM

E) Valleys

Ice dams can sometimes form at the junction of a roof where two different slopes meet. To provide a continuous path for melt water, run the cable up and down approximately two thirds of the valley as shown in the figure below.

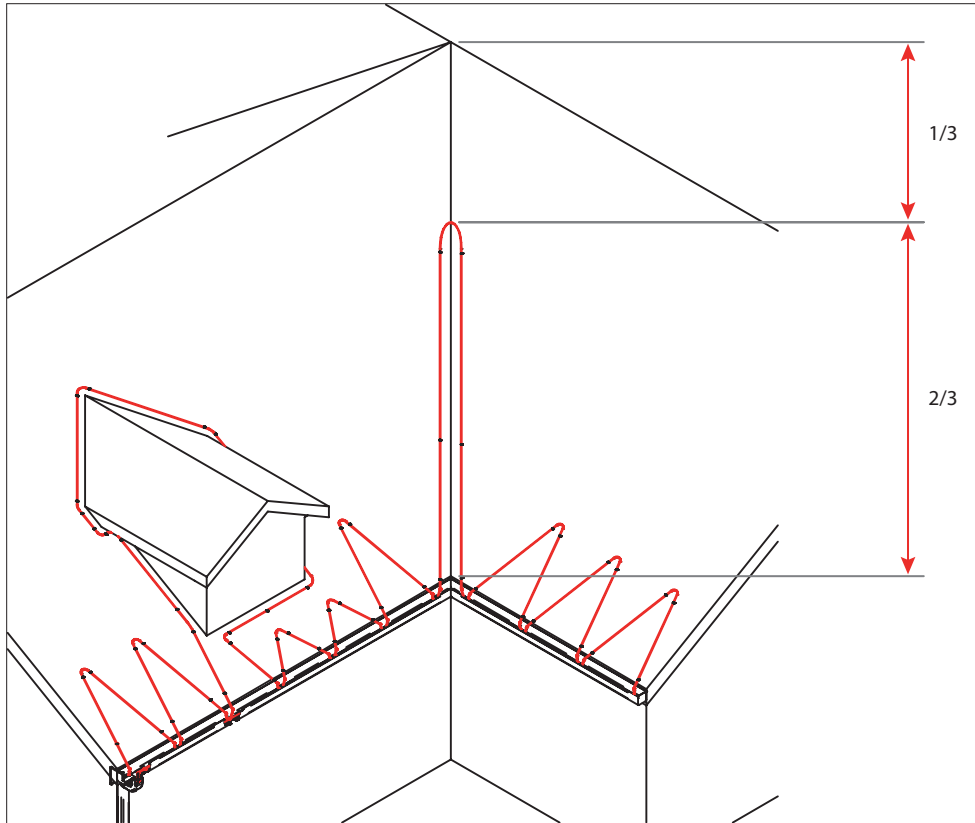

Figure 4: Valleys

Roof valley (in ft. x 0.67) x 2

Table 6: Valley cable length multiplier

F) Power connection

Always allow for and calculate a minimum of 36 in. (915 mm) per power junctions and connections.

Example calculation

Requirement for a 50 ft. shingle roof edge with a 12 in. overhang, two 25 ft. downspouts, a gutter widths of less than 6 in., single power connection. Use the calculation worksheet and multipliers provided in the tables below to calculate the heating circuit.

Roof and gutter heating cable calculation worksheet

Section	Calculation	Length
A) Roof edge	(12 in. overhang); 50 ft. x 2.0 ft.	100 ft.
B) Drain path/drip loops	50 ft. x 0.5	25 ft.
C) Gutters	50 ft. x 1	50 ft.
D) Downspouts	(25 ft. x 3) +1 ft.	76 ft.
E) Valleys	N/A	-
F) Power connection	3 ft.	3 ft.
TOTAL HEATING CABLE REQUIREMENT:		254 ft.

3. Heating cable selection

Determining maximum heating circuit length

The table below provides maximum circuit lengths of eltherm® ELSR-NA series heating cables. Choose the available circuit breaker rating, available voltage and minimum start-up temperatures provided in table below. If calculated heating circuit exceeds maximum allowable circuit length, the heating circuits will have to be split into additional heating circuits.

Models	Voltage	Max Circuit Breaker Rating	Max Circuit Length -10 °C (14 °F)	Max Circuit Length 0 °C (32 °F)
ELSR-NA-7-1-AO/BO	120V	15A	104 ft.	113 ft.
		20A	139 ft.	151 ft.
		30A	208 ft.	226 ft.
		40A	277 ft.	301 ft.
ELSR-NA-8-2-AO/BO	208V	15A	150 ft.	163 ft.
		20A	200 ft.	217 ft.
		30A	251 ft.	325 ft.
ELSR-NA-8-2-AO/BO	240V	40A	401 ft.	434 ft.
		15A	162 ft.	175 ft.
		20A	216 ft.	233 ft.
		30A	270 ft.	350 ft.
		40A	432 ft.	467 ft.



Self-regulating heat tracing cables must be installed with a ground fault circuit interrupter (GFCI), in compliance with the Canadian Electrical Code and the National Electrical Code. Please consult eltherm® ELSR-NA series data sheets for details or contact your local Ouellet Canada representative for more information.

4. Additional heat tracing requirements for flat roof drains

Roof drains are generally heat traced to prevent blockage from ice and snow. It is recommended to wrap the heating cable around the drain opening or cover and extend the heating cable at least 12 in. (305 mm) into the drain pipe to prevent blockage from ice. If building is unheat, extend the heating cable down to the storm sewer.

Install heating cable along the perimeter and flowing melt water paths (see figure for installation of cable on flat roof with center drain). On flat roof structure with external drains, run heating through scupper and provide sufficient heating cable to create drain loops on drains.

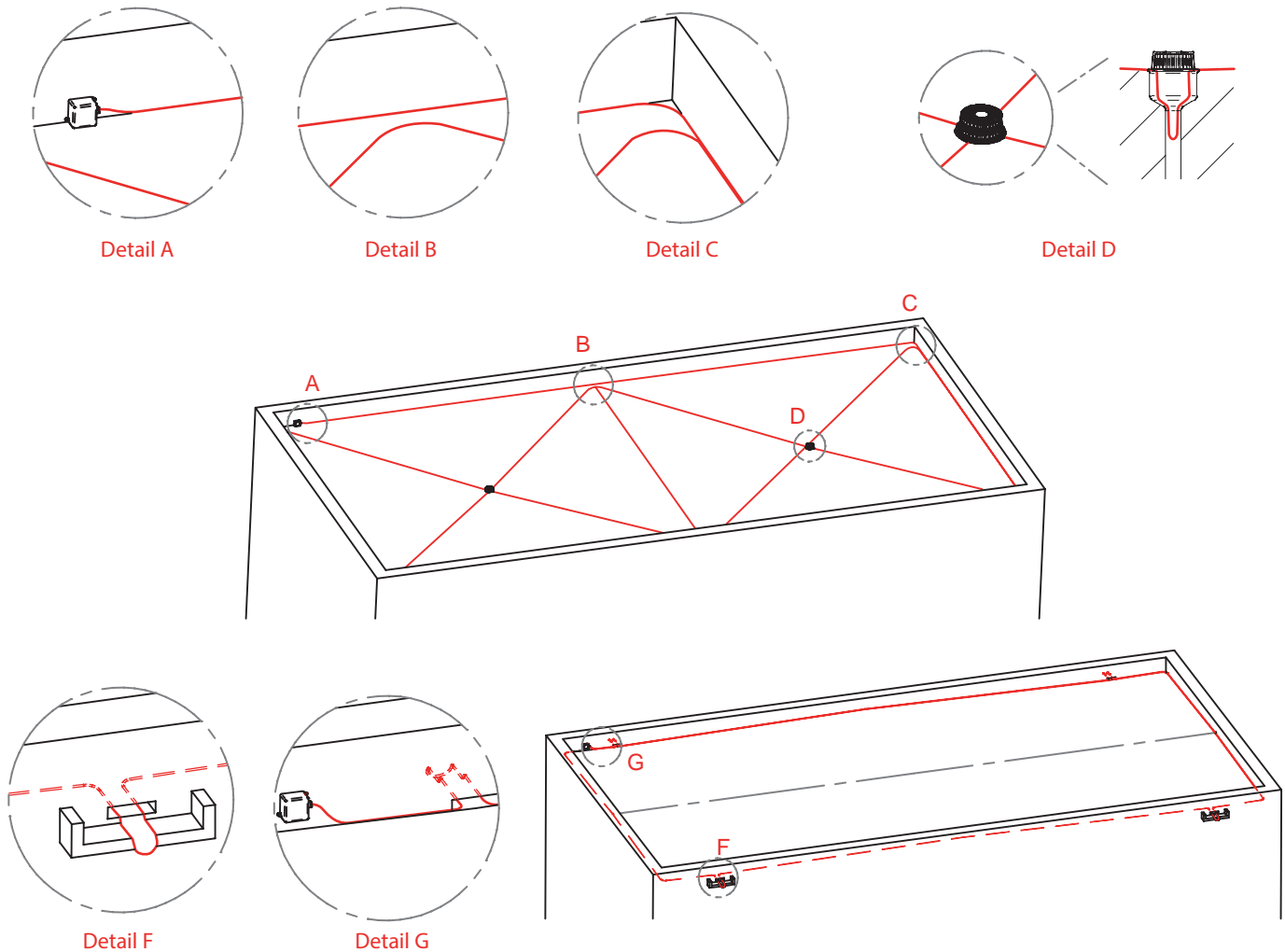

Figure 5: Flat roof drain and water path installation

5. Control systems for roof and gutter applications

Types of controls

a) Manual

Eltherm® ELSR series self-regulating heating cable does not require temperature sensing and monitoring equipment to operate under normal conditions. A simple on/off switch to cut off power may be used to disconnect the heating cable when ambient conditions do not require the continuous use of heating cables (e.g., when ambient temperature is above 4 °C (40 °F) for extended periods or when no precipitation, or significant accumulations of ice and snow are present).

b) Ambient sensing

Ambient sensing control turns power on and off when the ambient temperature reaches a point where it would be appropriate to turn on the power to the roof and gutter de-icing system based on the outside temperature of the sensing unit. This type of control eliminates the need to manually energize the circuit, but may switch on power when no precipitation (ice and/or snow) is present.

Carefully select the appropriate type of sensing system designed for roof and gutter installations, making sure it is suitable for use outdoors and for handling the circuit's power and current requirements.

c) Ambient sensing and precipitation sensors

The most efficient way to control power to the roof and gutter de-icing system is to provide automatic control that incorporates precipitation (ice, snow sensor) and ambient temperature monitoring designed to control power when ambient temperature and precipitation sensors detect significant accumulation and low temperature to energize the heating circuits to the roof and gutter installation.

Eltherm® and Ouellet Canada have extensive experience providing complete control systems capable of meeting any requirement. Please contact your nearest representative for information, or refer to Ouellet Canada catalog for details on the control systems available for various control modes.

Should your project exceed the scope of the design guide, please contact Ouellet Canada Technical Service at 1 800 463-7043 or visit us at www.ouellet.com.



B2

B

A

A9



Pipe tracing for
freeze protection
and temperature
maintenance

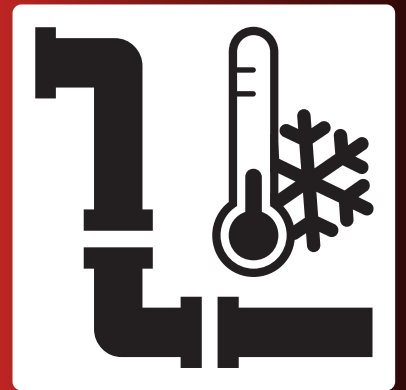

The requirement

Electric heat trace systems are designed to compensate for heat lost from insulated pipe and piping systems. While insulated pipes retain heat much longer than uninsulated pipes, the process temperature will eventually reach the surrounding ambient temperature. If ambient temperatures drop below freezing, an unsafe condition may arise if the components within the pipe fall below freezing temperatures.

Self-regulating heating cables offer a flexible and economical solution for heat loss prevention applications on pipes and piping installations. The technology can be applied to metal or plastic pipes, can be cut to length in the field and overlapped without running the risk of overheating.

The solution

Eltherm® ELSR series self-regulating heating cables have been specifically developed and optimized to provide freeze protection and process temperature maintenance in commercial, residential and industrial pipe heat tracing applications. Eltherm® ELSR-NA and ELSR-MA heating cable are suitable for low and medium temperature applications, and a high temperature version ELSR-HA heating cable is available for temperatures up to 200 °C (392 °F). Matching accessories complete our product offering.

All eltherm® heating cables have been approved by all major national and international heat tracing standards, ELSR-NA and ELSR-HA heat tracing products are also approved and certified for use in hazardous areas.

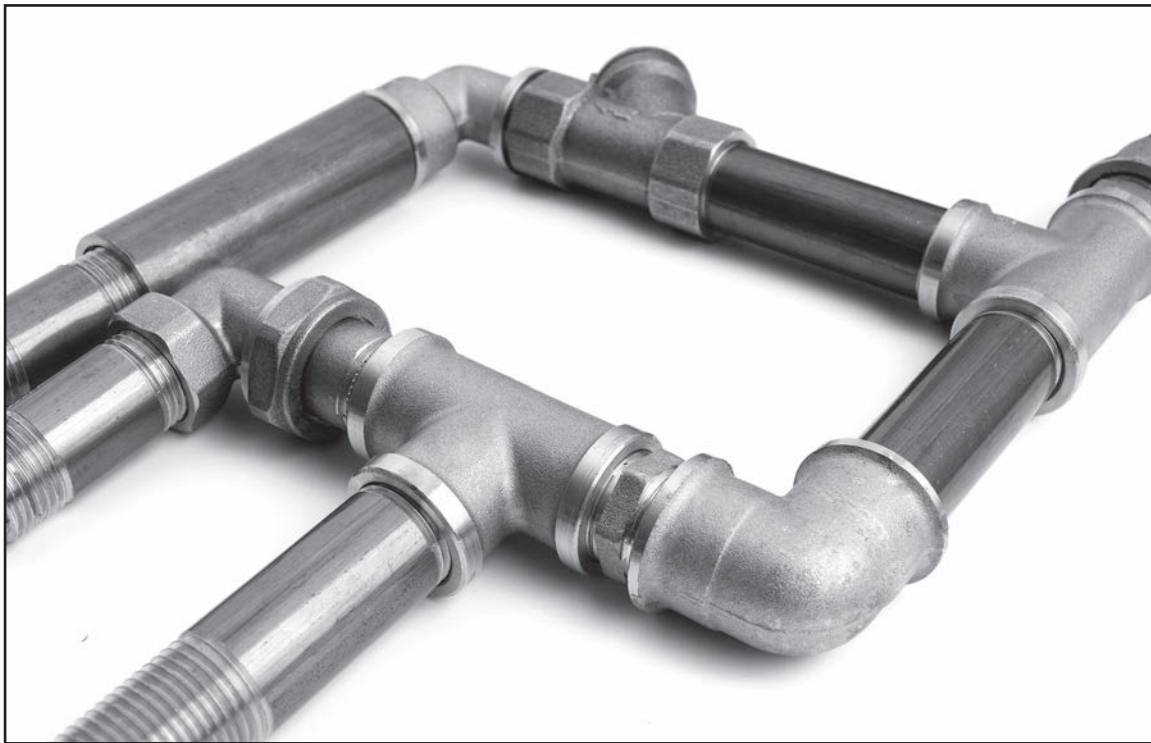

Selecting the proper cable

Eltherm® ELSR-NA and ELSR-MA Series Self-Regulating Heat Tracing Products for Commercial and Residential Piping Systems.

Product description and application information

Eltherm®'s ELSR-NA and ELSR-MA line of self-regulating heating cables are designed to provide supplemental heat for freeze protection and low temperature to 60 °C (140 °F) maintain applications in commercial and residential pipe applications. All NA and MA series heating cable types are approved for use in non-hazardous (ordinary) as well as outdoor installations (wet rated and UV resistant). NA series are also approved for use in hazardous locations.

Product configuration options

Type AO

The AO cable is a unique, easy-to terminate, light weight cable designed exclusively for low and medium temperature applications and constructed to save installation time and costs. The AO cable design features an aluminum foil shield and thermoplastic outer jacket.



Type BO and BOT

The classic self-regulating heating cable design features a protective tin-plated copper braid and a thermoplastic outer jacket (BO). A fluoropolymer outer jacket (BOT) is also available to provide maximum resistance against aggressive chemicals, oil and fuels.



Ratings and approvals

Available Cable Types and Output:

120V:

240/208V:

Minimum Installation Temperature:

Minimum Bend Radius:

Certifications:

ELSR-NA

3, 5, 7W/ft. @ 50 °F

4, 6, 8, 10W/ft. @ 50 °F

- 30 °C (- 22 °F)

1 in. (25 mm)

CSA C22.2.130; -WS

CAN/CSA 60079-7:12, 60079-0-11

ANSI/IEEE 515.1, 515.1



ELSR-MA

3, 5W/ft. @ 50 °F

3, 5W/ft. @ 50 °F

- 30 °C (- 22 °F)

1 in. (25 mm)

IEEE 515, CSA 22.2 130.03



PIPE TRACING FOR FREEZE PROTECTION AND TEMPERATURE MAINTENANCE

Ordering information

For more information, consult our catalogue or visit us at www.ouellet.com.

Heating Cable Type	Model Number	Specification (at 41 °F)
ELSR-NA-AO Aluminum Shield Tinned Copper Ground Wire Thermoplastic Outer Jacket	ELSR-NA-3-1-AO	3W/ft. @ 120V
	ELSR-NA-5-1-AO	5W/ft. @ 120V
	ELSR-NA-7-1-AO	7W/ft. @ 120V
	ELSR-NA-4-2-AO	4W/ft. @ 240V
	ELSR-NA-6-2-AO	6W/ft. @ 240V
	ELSR-NA-8-2-AO	8W/ft. @ 240V
	ELSR-NA-10-2-AO	10W/ft. @ 240V
ELSR-NA-BO Classic Tinned Copper Braid Thermoplastic Outer Jacket	ELSR-NA-3-1-BO	3W/ft. @ 120V
	ELSR-NA-5-1-BO	5W/ft. @ 120V
	ELSR-NA-7-1-BO	7W/ft. @ 120V
	ELSR-NA-4-2-BO	4W/ft. @ 240V
	ELSR-NA-6-2-BO	6W/ft. @ 240V
	ELSR-NA-8-2-BO	8W/ft. @ 240V
	ELSR-NA-10-2-BO	10W/ft. @ 240V
ELSR-NA-BOT Classic Tinned Copper Braid Fluoropolymer Outer Jacket	ELSR-NA-3-1-BOT	3W/ft. @ 120V
	ELSR-NA-5-1-BOT	5W/ft. @ 120V
	ELSR-NA-7-1-BOT	7W/ft. @ 120V
	ELSR-NA-4-2-BOT	4W/ft. @ 240V
	ELSR-NA-6-2-BOT	6W/ft. @ 240V
	ELSR-NA-8-2-BOT	8W/ft. @ 240V
	ELSR-NA-10-2-BOT	10W/ft. @ 240V
ELSR-MA-AO Aluminum Shield Tinned Copper Ground Wire Thermoplastic Outer Jacket	ELSR-MA-3-1-AO	3W/ft. @ 120V
	ELSR-MA-5-1-AO	5W/ft. @ 120V
	ELSR-MA-3-2-AO	3W/ft. @ 240V
	ELSR-MA-5-2-AO	5W/ft. @ 240V
ELSR-MA-BO Classic Tinned Copper Braid Thermoplastic Outer Jacket	ELSR-MA-3-1-BO	3W/ft. @ 120V
	ELSR-MA-5-1-BO	5W/ft. @ 120V
	ELSR-MA-3-2-BO	3W/ft. @ 240V
	ELSR-MA-5-2-BO	5W/ft. @ 240V

Table 1: Recommended heating cable

Self-regulating heating cables for pipe applications

The main objective of any pipe heating application is to prevent freezing or to maintain the temperature of a material, gas or process, or to compensate for heat losses that cannot be adequately prevented through of insulation.

Some of the most common electrical pipe surface heating applications:

- Freeze protection of indoor or outdoor cold water supply system piping
- Wastewater pipes
- Water service and sprinkler systems
- Fire protection piping
- Drain and collector piping systems
- Freezer drain and collector piping
- Pipe instrumentation (meters, gauges, valves)

Key design notes, basis for a good design

The first step in designing an electrical surface heating system is to determine the heat loss of the piping system to be heat traced.

To calculate the heat loss, you must collect the following information:

- Pipe size (diameter) and length of pipe to be heated
- Pipe material type (e.g., plastic or metal)
- Required maintain temperature
- Minimum (coldest, lowest) ambient temperature
- Number of fittings, flanges, supports or other heat sinks
- Insulation type (material) and thickness
- Voltage (120V or 240/208V)

Calculating heat loss for freeze protection applications in pipelines

This design guide provides information for calculating heating cable requirements in freeze protection applications (maintain temperature of 5 °C or 40 °F).

Table 1 provides a step-by-step guide for gathering the information needed to determine the required heating cable for a given application.

Pipe heating calculation information worksheet Freeze protection

Design Parameter	Description	Value
A) Pipe size	Pipe size (inches or mm DN)	_____ in. (DN)
B) Pipe length	Total length of pipe required for heat tracing (ft.) or (m)	_____ ft. (m)
C) Pipe material	Metallic or non-metallic*	_____
D) Min. ambient temperature	Coldest ambient temperature the pipe will be exposed to	_____ (°C/°F)
E) Maintain temperature	Enter 5 °C (40 °F) for freeze protection applications	5 °C (40 °F)
F) Valves, flanges, fittings	Add number of flanges, fittings, pumps or valves	_____ (qty)
G) Pipe supports	Add number of non-insulated pipe supports	_____ (qty)
H) Terminations, splices, connections	Add number of connections and terminations	_____ (qty)
I) Supply voltage	Voltages available at point of installation or facility	_____ (V)

* For installation of heating cables on plastic pipes, multiply required heating cable by a factor of 1.8 and follow eltherm® recommended installation guidelines.



Note

All calculations, design data and heat loss calculations provided are based on insulated piping with glass fiber or mineral wool insulation, installed outdoors with 20mph (32kph) wind speed and 20% safety factor

PIPE TRACING FOR FREEZE PROTECTION AND TEMPERATURE MAINTENANCE

Step 1: Determine heating cable requirement

After the information has been gathered, use Table 2 for 120V units, and Table 3 for 240V units to determine the type and quantity of heating cable required for the application.

120V		Design guide freeze protection 5 °C (40 °F) self-regulating parallel heating cables types ELSR-NA-3-1-BO(T), ELSR-NA-5-1-BO(T), ELSR-NA-7-1-BO(T)															
Pipe size	Inches: DN	1/2 15	3/4 20	1 25	1 1/4 32	1 1/2 40	2 50	2 1/2 65	3 80	4 100	5 125	6 150	7 175	8 200	9 225	10 250	12 300
Insulation thickness in. (mm)	Ambient temperature min. °C (°F)	y for heater type ELSR-NA-y-1-BO(T)															
0.4 (10)	-15 (5)	3	5	5	5	7	7	2x5	2x5	2x7	3x5	3x7	3x7	4x7	4x7	4x7	5x7
	-20 (-5)	5	5	7	7	7	2x5	2x7	2x7	3x7	3x7	4x7	4x7	4x7	5x7	5x7	6x7
	-25 (-15)	5	7	7	2x5	2x5	2x7	2x7	3x5	3x7	4x7	4x7	5x7	5x7	6x7	6x7	7x7
0.8 (20)	-15 (5)	3	3	3	3	3	5	5	7	7	2x5	2x5	2x7	2x7	3x7	3x7	3x7
	-20 (-5)	3	3	3	5	5	5	7	7	2x5	2x5	2x7	2x7	3x5	3x7	3x7	3x7
	-25 (-15)	3	5	5	5	5	7	7	2x5	2x5	2x7	2x7	3x7	3x7	3x7	4x7	4x7
1.2 (30)	-15 (5)	3	3	3	3	3	3	5	5	7	7	7	7	2x5	2x5	2x5	2x7
	-20 (-5)	3	3	3	3	3	5	5	5	7	7	2x5	2x5	2x7	2x7	2x7	3x5
	-25 (-15)	3	3	3	5	5	5	5	7	7	2x5	2x5	2x7	2x7	2x7	3x7	3x7
1.6 (40)	-15 (5)	3	3	3	3	3	3	3	5	5	5	5	7	7	7	7	2x5
	-20 (-5)	3	3	3	3	3	3	5	5	5	7	7	7	2x5	2x5	2x5	2x7
	-25 (-15)	3	3	3	3	3	5	5	5	7	7	2x5	2x5	2x5	2x7	2x7	2x7
2 (50)	-15 (5)	3	3	3	3	3	3	3	3	5	5	5	7	7	7	7	7
	-20 (-5)	3	3	3	3	3	3	3	5	5	7	7	7	7	7	2x5	2x5
	-25 (-15)	3	3	3	3	3	3	5	5	5	7	7	2x5	2x5	2x5	2x5	2x5
2.4 (60)	-15 (5)	3	3	3	3	3	3	3	3	3	5	5	5	7	7	7	5
	-20 (-5)	3	3	3	3	3	3	3	3	5	5	5	7	7	7	7	2x5
	-25 (-15)	3	3	3	3	3	3	3	5	5	5	7	7	7	2x5	2x5	2x7
3.2 (80)	-15 (5)	3	3	3	3	3	3	3	3	3	3	3	3	5	5	5	7
	-20 (-5)	3	3	3	3	3	3	3	3	3	5	5	5	5	5	7	7
	-25 (-15)	3	3	3	3	3	3	3	3	5	5	5	5	7	7	7	2x5
4 (100)	-15 (5)	3	3	3	3	3	3	3	3	3	3	3	3	3	5	5	5
	-20 (-5)	3	3	3	3	3	3	3	3	3	3	3	3	3	5	5	5
	-25 (-15)	3	3	3	3	3	3	3	3	3	5	5	5	5	7	7	7

Basis: thermal conductivity of the insulation 0.04 W/(mK); safety addition 20%.

Basis: thermal conductivity of the insulation 0.021 BTU/(hr ft. °F); safety addition 20%.

Table 2: 120V Heating cable requirement

240V		Design guide freeze protection 5 °C (40 °F) self-regulating parallel heating cables types ELSR-NA-4-2-BO(T), ELSR-NA-6-2-BO(T), ELSR-NA-8-2-BO(T), ELSR-NA-10-2-BO(T)															
Pipe size	Inches: DN	1/2 15	3/4 20	1 25	1 1/4 32	1 1/2 40	2 50	2 1/2 65	3 80	4 100	5 125	6 150	7 175	8 200	9 225	10 250	12 300
Insulation thickness in. (mm)	Ambient temperature min. °C (°F)	y for heater type ELSR-NA-y-2-BO(T)															
0.4 (10)	-15 (5)	4	4	6	6	6	6	8	10	2x6	2x8	2x10	2x10	3x8	3x8	3x10	3x10
	-20 (-5)	4	6	6	6	8	10	10	2x6	2x8	2x10	2x10	3x8	3x10	3x10	4x10	4x10
	-25 (-15)	6	6	6	8	10	10	2x6	2x8	2x10	2x10	3x8	3x10	3x10	4x10	4x10	5x10
0.8 (20)	-15 (5)	4	4	4	4	4	4	6	6	6	8	10	10	2x6	2x6	2x8	2x8
	-20 (-5)	4	4	4	4	6	6	6	6	8	10	2x6	2x6	2x8	2x8	2x10	2x10
	-25 (-15)	4	4	4	6	6	6	6	8	10	2x6	2x8	2x8	2x10	2x10	3x8	3x10
1.2 (30)	-15 (5)	4	4	4	4	4	4	4	4	6	6	6	8	8	10	10	2x6
	-20 (-5)	4	4	4	4	4	4	6	6	6	8	10	10	2x6	2x6	2x8	2x8
	-25 (-15)	4	4	4	4	4	6	6	6	8	10	2x6	2x6	2x8	2x8	2x10	2x10
1.6 (40)	-15 (5)	4	4	4	4	4	4	4	4	4	6	6	6	6	6	8	10
	-20 (-5)	4	4	4	4	4	4	4	4	6	6	6	8	8	10	10	2x6
	-25 (-15)	4	4	4	4	4	4	6	6	6	8	10	10	10	10	2x6	2x6
2 (50)	-15 (5)	4	4	4	4	4	4	4	4	4	4	6	6	6	6	6	8
	-20 (-5)	4	4	4	4	4	4	4	4	4	6	6	6	6	8	8	10
	-25 (-15)	4	4	4	4	4	4	4	6	6	6	8	8	10	10	10	2x6
2.4 (60)	-15 (5)	4	4	4	4	4	4	4	4	4	4	4	6	6	6	6	6
	-20 (-5)	4	4	4	4	4	4	4	4	4	6	6	6	6	6	8	8
	-25 (-15)	4	4	4	4	4	4	4	4	6	6	6	6	6	8	8	10
3.2 (80)	-15 (5)	4	4	4	4	4	4	4	4	4	4	4	4	4	4	6	6
	-20 (-5)	4	4	4	4	4	4	4	4	4	4	4	4	4	6	6	6
	-25 (-15)	4	4	4	4	4	4	4	4	4	6	6	6	6	6	6	8
4 (100)	-15 (5)	4	4	4	4	4	4	4	4	4	4	4	4	4	4	4	6
	-20 (-5)	4	4	4	4	4	4	4	4	4	4	4	4	4	4	6	6
	-25 (-15)	4	4	4	4	4	4	4	4	4	4	4	4	4	6	6	6

Basis: thermal conductivity of the insulation 0.04 W/(mK); safety addition 20%.

Basis: thermal conductivity of the insulation 0.021 BTU/(hr ft. °F); safety addition 20%.

Table 3: 240V Heating cable requirement

PIPE TRACING FOR FREEZE PROTECTION AND TEMPERATURE MAINTENANCE

Step 2: Calculate heating cable requirements for heat sinks, connections and terminations

Additional heating cable is required for any heat sinks located on the pipelines. These may include flanges, pumps, valves and uninsulated pipe supports. Table 4 provides details on any additional heating cable amounts to be added to the project for the various heat sinks, as well as the addition of heating cables to be taken into account for terminations into junction boxes (power terminations), thermostats and splices. For splices, add the same amount of heating cable as provided for connections to junctions boxes.

		Heater allowances ft. (m) for															
Inches:		1/2	3/4	1	1 1/4	1 1/2	2	2 1/2	3	4	5	6	7	8	9	10	12
DN		15	20	25	32	40	50	65	80	100	125	150	175	200	225	250	300
Pair of flanges	ft. (m)	0.6 (0.2)	0.6 (0.2)	0.8 (0.25)	1 (0.3)	1 (0.3)	1.2 (0.35)	1.3 (0.4)	1.6 (0.5)	2 (0.6)	2.3 (0.7)	2.6 (0.8)	3 (0.9)	3.3 (1)	3.6 (1.1)	4.3 (1.3)	5 (1.5)
Flanged fitting	ft. (m)	1.3 (0.4)	1.5 (0.45)	1.6 (0.5)	1.8 (0.55)	2 (0.6)	2.6 (0.8)	3 (0.9)	3.6 (1.1)	5 (1.5)	6.5 (2)	8 (2.4)	9.2 (2.8)	11 (3.3)	12.5 (3.8)	13.8 (4.2)	16.5 (5)
Pumps	ft. (m)	5 (1.5)	5 (1.5)	6.5 (2)	6.5 (2)	8.2 (2.5)	8.2 (2.5)	10 (3)	13 (4)	16.5 (5)	16.5 (5)	20 (6)	20 (6)	21 (6.5)	21 (6.5)	23 (7)	26 (8)

For each non-insulated pipe support, additional heater length required: 4x support width.

Attention: If there is multiple tracing on pipes, the allowances above must be multiplied accordingly. Also allow approx 2 ft. (0.6 m) of additional heater length for each connection in terminal/junction box or field mounted thermostat.

Table 4: Heating cable adders for flanges, pipe supports

Example

A customer requires an 80 ft. section of 4 in. metal insulated pipe (2 in. mineral wool insulation) to be heat traced for freeze protection. In addition, the pipe includes 2 pairs of flanges, one flange fitting (thread) and four uninsulated pipe supports, 1/2 in. wide. The lowest expected ambient temperature is -20 °C (-5 °F).

Using the information worksheet, sort the gathered information. Then, using the heating cables requirement tables provided, locate the required cable type in the columns provided (highlighted in red for the example provided) and add the lengths of the cables and the additional heat sinks.

Pipe heating calculation information worksheet Freeze protection

Design Parameter	Description	Value	Heating Cable Required
A) Pipe size	Pipe size (in. or mm DN)	4 in. (DN)	-
B) Pipe length	Total length of pipe required for heat tracing (ft.) or (m)	80 ft.	80 ft.
C) Pipe material	Metallic or non-metallic*	metal	-
D) Min. ambient temperature	Coldest ambient temperature the pipe will be exposed to	-5 °F (-20 °C)	-
E) Maintain temperature	Enter 40 °F (5 °C) for freeze protection applications	40 °F (5 °C)	-
F) Valves, flanges, fittings	Add number of flanges, fittings, pumps or valves	2 flanges, 1 fitting, 1 pump	25.5 ft.
G) Pipe supports	Add number of non-insulated pipe supports	4	8 ft.
H) Terminations, splices, connections	Add number of connections and terminations	1	2 ft.
I) Supply voltage	Voltages available at point of installation or facility	120V	-
RECOMMENDED HEATING CABLE (from Table 1): ELSR-NA-5-1-AO/BO/BOT		-	-
Required Quantity:			115.5 ft.

* For installation of heating cables on plastic pipes, multiply required heating cable by a factor of 1.8 and follow eltherm® recommended installation guidelines.

PIPE TRACING FOR FREEZE PROTECTION AND TEMPERATURE MAINTENANCE

Step 3: Determine required heating cable circuits

Tables provide the maximum heating circuit lengths of eltherm®'s ELSR-NA self-regulating heating cables, for 120V and 240V operation.

Heating Circuit Length for ELSR-NA Models

120V					240V					
Start-up temperature	CB capacity (A)	Maximum heating circuit (ft.) for			Start-up temperature	CB capacity (A)	Maximum heating circuit (ft.) for			
		ELSR-NA-3-1	ELSR-NA-5-1	ELSR-NA-7-1			ELSR-NA-4-2	ELSR-NA-6-2	ELSR-NA-8-2	ELSR-NA-10-2
10 °C (50 °F)	10	159	125	82	10 °C (50 °F)	10	273	170	127	66
	15	238	187	123		15	410	255	191	99
	20	317	249	164		20	547	340	255	132
	25	397	312	205		25	683	425	318	165
	30	476	374	246		30	820	510	382	198
	35	555	436	287		35	957	595	446	231
	40	612	499	328		40	1087	857	509	264
0 °C (32 °F)	10	143	112	75	0 °C (32 °F)	10	245	154	117	61
	15	215	168	113		15	367	231	175	91
	20	287	224	151		20	489	308	233	121
	25	358	280	188		25	612	385	292	152
	30	430	336	226		30	734	462	350	182
	35	502	392	264		35	856	539	408	212
-10 °C (14 °F)	10	130	102	69	-10 °C (14 °F)	10	222	141	108	57
	15	195	153	104		15	333	211	162	85
	20	260	204	139		20	444	281	216	113
	25	325	255	173		25	555	352	270	142
	30	390	306	208		30	666	422	324	170
	35	455	357	243		35	777	492	378	198
	40	520	408	277		40	888	563	432	227
-30 °C (-22 °F)	10	110	87	60	-30 °C (-22 °F)	10	187	120	93	50
	15	165	130	90		15	280	180	140	75
	20	220	173	120		20	373	240	187	100
	25	275	217	150		25	467	300	233	125
	30	330	260	180		30	560	360	280	150
	35	385	303	210		35	653	420	327	175
40	440	347	240	40	747	480	373	200		

If the circuit breaker rating for the heating circuit is known, match the rating with the selected cable and the minimum operating temperature at which the cable will be energized.

If the circuit breaker is not known, find the maximum circuit length that meets or exceeds the length of the selected cable and minimum start-up temperature and determine the circuit breaker size (required amperage) provided in the tables.



Self-regulating heat tracing cables must be installed with a ground fault circuit interrupter (GFCI), in compliance with the Canadian Electrical Code and the National Electrical Code. Please consult eltherm® ELSR-NA series data sheets for details or contact your local Ouellet Canada representative for more information.

Step 4: Choose installation accessories

A complete heat tracing installation for freeze protection of pipes typically includes the following components:

- Self-regulating heating cables
- Power connection kits
- End termination kits
- Splices and tees as required
- Junction boxes
- Temperature monitoring and/or control

Item	Model Number	Description
Heating Cable		
1	ELSR-NA-X-X-XX (X)	ELSR-NA self-regulating heating cable, 120V, 240/208V
Termination and Connection Kits		
2	KIT-OSR-ELSR-NA	End and power termination kit with warning sticker NA Series
Installation/Mounting Accessories		
3	ELB-0X	Self-adhesive tape
4	KIT-OSR-EL-WS03	Warning label/sign bilingual
Control and Monitoring (possible options)		
5	ECA-E55-R25HT ¹	SPDT, NEMA 4X thermostat in molded aluminum housing, 22A at 120/250/480V, with 10 ft. (3 m) stainless steel bulb and capillary
5	TRF115-005 ¹	SPDT, NEMA 4X thermostat, range -17 °C to 49 °C (0 °F to 120 °F), 25A at 120/208/240/277V, with 5 ft. (1.5 m) stainless steel bulb and capillary

¹ Requires a ground fault circuit interrupter (GFCI) in the electrical panel.

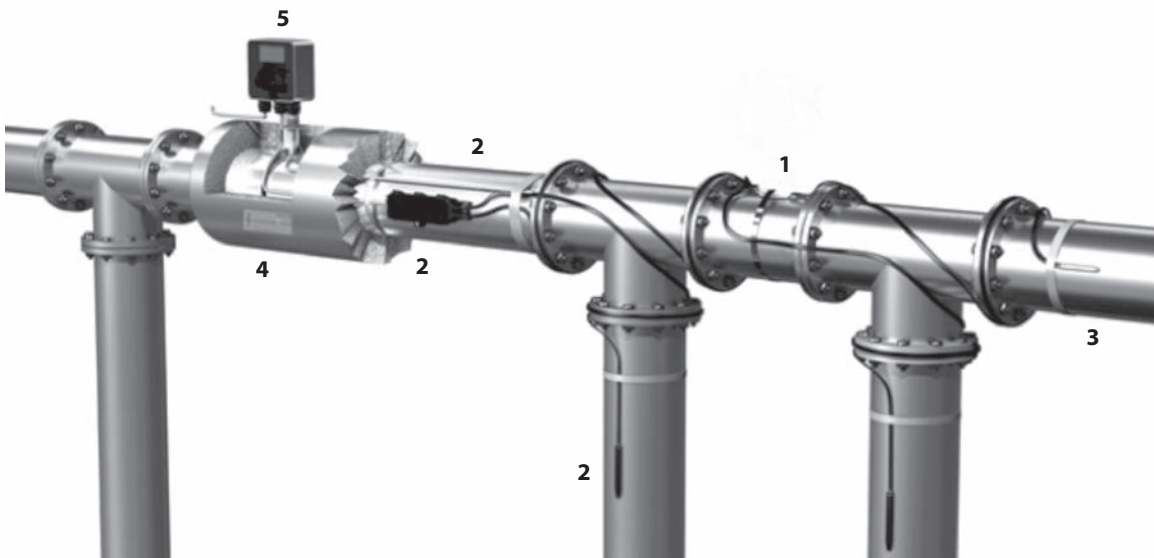

Project notes/tips

Application of self-regulating heating cable on pipes

The following design tips are provided as a basic guideline for the proper installation of eltherm® self-regulating heating cables on pipes and pipeline applications. For additional detail, please review eltherm®'s ELSR-NA and ELSR-HA installation manual (document QAA-85).

Device protection/heating cable circuit protection:

- A ground fault protection device GFCI (30mA, or 30mA above the inherent fault current level of the installation) must be used for each heating circuit.
- Metallic braid or screen of the heating cable must be connected to ground (potential earth).
- De-energize all circuits prior to installation or maintenance of heating components.
- All work must be carried out in compliance with all codes and regulations in force.
- To avoid short circuits, do not connect the two bus wires of the heating cable to each other.
- Always observe termination and maintenance instructions for the connection and termination of the heating cables.

Basic installation notes

Prior to the application of heating cables on the surface of pipes, please review the following instructions:

- Remove any sharp objects on the surface to be heated.
- Clean and degrease the surface.
- Installation of self-regulating heating circuit componentry must be carried out using original eltherm® accessories according to eltherm® installation instructions.
- Maintain minimum of 1 in. (25 mm) bend radius as provided in the product data sheets.
- When applying and fastening self-regulating heating cables, use self-adhesive glass fiber tape or pre-punched (stainless) steel fastening strips (for low temperature applications ELSR-NA, plastic cable ties may also be used).
Attention: Do not use adhesive tape with emollients (PVC).
- The heating cable should be fully covered (the entire length) with aluminum foil to prevent insulation material from slipping between the cable and surface to be heated. If insulation is covered with metal cladding, an insulation entry kit should be used to avoid mechanical damage of the heating cable.
- For installation on plastic piping, eltherm® highly recommends applying a layer of aluminum foil over the pipe prior to the application of the heating cable. This aids in heat transfer.
- Upon completion of the installation, the heating circuit must be marked with an appropriate label to the associated junction box or to the heating cable close to the junction box. The label should be weatherproof and contain relevant information on all components used.
- Electrically heated parts must be identified in reasonable distances along the pipe with warning labels "Electrical Heating" placed on top of thermal insulation (approx. 15 ft./5 m distance between each label on pipelines or at least one warning label per pipe-branch).

Installation recommendation for pipes control and monitoring

The heating cable is traced and fixed parallel to the pipe axis.

Hazardous area: a max. 300 mm

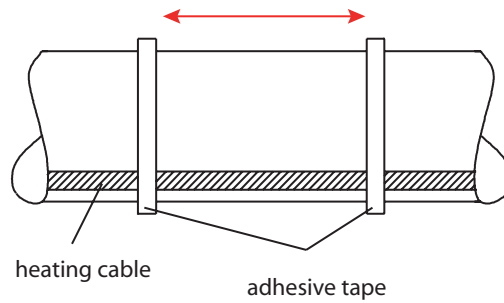
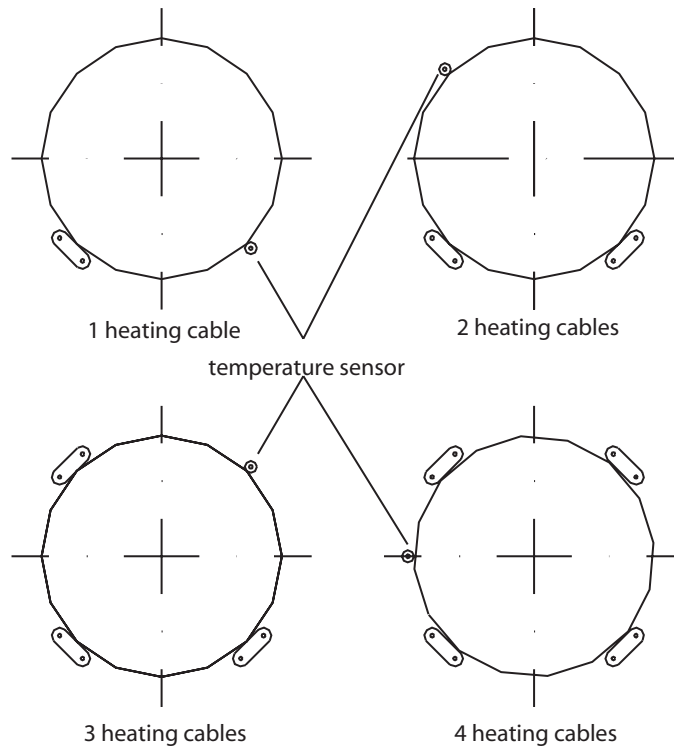

Figure 1: Application of heating cable on pipe using adhesive tape



Heating cable recommended single and multiple parallel runs on pipe, including location of temperature sensors where applicable

Control systems for pipe freeze protection applications

Eltherm® ELSR series self-regulating heating cables do not require temperature sensing and monitoring equipment to operate under normal conditions. Temperature sensing and control in freeze protection applications are used to provide a means to disconnect power to the system for energy conservation and optimum operation.

The two most common control methods in pipe applications are to use ambient air sensors or pipe wall sensors.

Ambient sensing

Ambient sensing control turns power on and off when the ambient temperature reaches a point where it would be appropriate to turn on the power. This type of control eliminates the need to manually energize the circuit. The thermostat or temperature switch and sensor are set to energize the heating circuit at a pre-determined ambient temperature. Sensing equipment is placed at a location near the heating circuit.

Pipe wall sensing

Line sensing control is used for process maintenance applications or freeze protection applications where the process temperature must be controlled within a moderate or narrow band. In a pipe wall sensing control system, a thermostat or RTD is used to sense pipe wall temperature and switch the heating cable on and off at a preset temperature.

Select the appropriate type of sensing system from the options provided in the control hardware section of the design guide. It is important to choose line sensing or ambient thermostat systems suitable to handle the current rating of the heating circuit.

Eltherm® and Ouellet Canada has extensive experience in custom sensing and temperature control systems. Please contact your nearest representative for information, or refer to Ouellet Canada catalog for details.

Should your project exceed the scope of the design guide, please contact Ouellet Canada Technical Service at 1 800 463-7043 or visit us at www.ouellet.com.

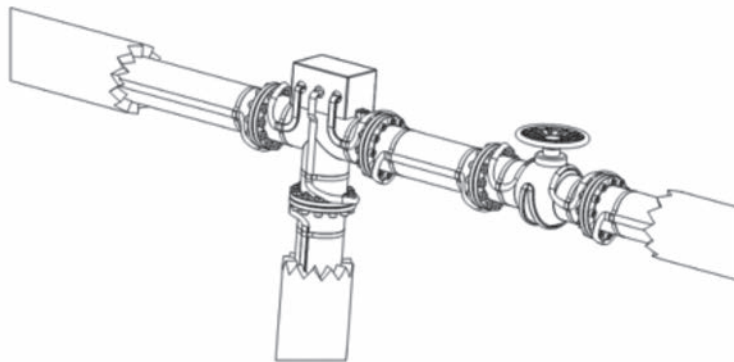





Data sheets, options,
accessories and
design forms

ELSR-NA

Features

Surgaine

- Thermoplastic (AO, BO), Fluoropolymer (BOT).

Bus wire

- Nickel plated copper.

Minimum start-up temperature

- -30 °C (-22 °F).

Maximum operating temperature (power on)

- 60 °C (140 °F).

Maximum operating temperature (power off)

- 80 °C (176 °F).

Nominal voltage

- 120V, 240V.

Bending radius, minimum

- 25 mm (1 in.).

Installation temperature, minimum

- AO, BO: -45 °C (-45 °F).
- BF: -25 °C (-13 °F).

Classification

- II 2G Ex e IIC T6 Gb II 2D Ex tb IIIC.
- T 80 °C Db.
- Class I, Division 2, Groups A, B, C, D.
- Class II, Division 2, Groups E, F, G.
- Class III, T6.
- Class I, Zone 1, AEx / Exe II, T6.
- Class 1, Division 1, Groups B, C, D (Contact manufacturer).

Standards

- CSA C22.2.130.03; -WS.
- CAN/CSA 60079-7:12, 60079-0-11.
- ANSI/IEEE 515, 515.

Certification

- IECEx EPS 12.0006U.
- 12ATEX1431U.
- CSA C US 2547790

Rating

- Wet rated, for outdoor use (WS).

Warranty

- 1-year basic warranty on the heating cable.
- 10-year limited warranty available.

Application

- Freeze protection, heat tracing instrumentation, pipes, vessel and tanks, chemical and petrochemical industries, food processing, automotive, roof and gutter, sprinkler systems.

Heating circuit length for ELSR-NA models

Start-up temperature	120V			
	CB capacity (A)	Maximum heating circuit (ft.) for		
		ELSR-NA-3-1	ELSR-NA-5-1	ELSR-NA-7-1
10 °C (50 °F)	10	159	125	82
	15	238	187	123
	20	317	249	164
	25	397	312	205
	30	476	374	246
	35	555	436	287
0 °C (32 °F)	10	143	112	75
	15	215	168	113
	20	287	224	151
	25	358	280	188
	30	430	336	226
	35	502	392	264
-10 °C (14 °F)	10	130	102	69
	15	195	153	104
	20	260	204	139
	25	325	255	173
	30	390	306	208
	35	455	357	243
-30 °C (-22 °F)	10	110	87	60
	15	165	130	90
	20	220	173	120
	25	275	217	150
	30	330	260	180
	35	385	303	210
40	440	347	240	

Start-up temperature	240V				
	CB capacity (A)	Maximum heating circuit (ft.) for			
		ELSR-NA-4-2	ELSR-NA-6-2	ELSR-NA-8-2	ELSR-NA-10-2
10 °C (50 °F)	10	273	170	127	66
	15	410	255	191	99
	20	547	340	255	132
	25	683	425	318	165
	30	820	510	382	198
	35	957	595	446	231
0 °C (32 °F)	10	245	154	117	61
	15	367	231	175	91
	20	489	308	233	121
	25	612	385	292	152
	30	734	462	350	182
	35	856	539	408	212
-10 °C (14 °F)	10	222	141	108	57
	15	333	211	162	85
	20	444	281	216	113
	25	555	352	270	142
	30	666	422	324	170
	35	777	492	378	198
-30 °C (-22 °F)	10	187	120	93	50
	15	280	180	140	75
	20	373	240	187	100
	25	467	300	233	125
	30	560	360	280	150
	35	653	420	327	175
40	747	480	373	200	

Maximum heating circuit ELSR-NA-XX on the following conditions:

- 120V, 240V
- Voltage drop max. 10%
- MCB type QO (100% utilization)
- Single cable fed 1 end

ELSR-NA-XX-1-BOT output (on insulated metallic pipes)

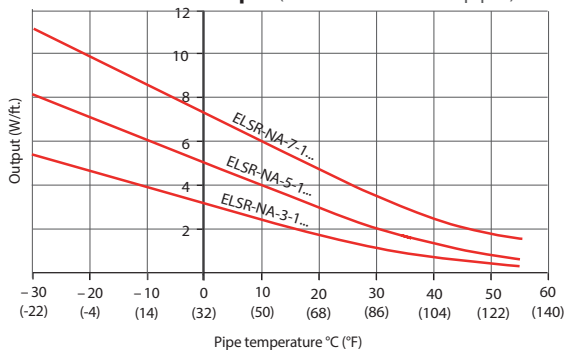

ELSR-NA-XX-2-BOT output (on insulated metallic pipes)

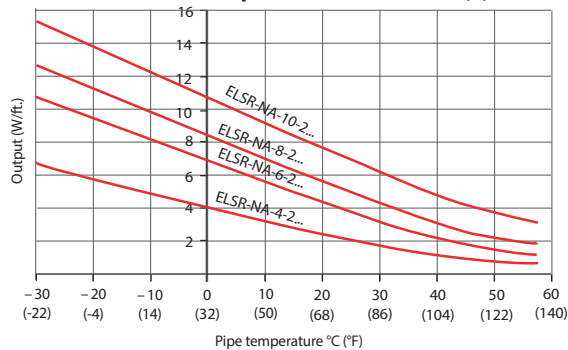

ELSR-MA

Features

Outer jacket

- Thermoplastic (AO, BO), Fluoropolymer (BF).

Bus wire

- Nickel plated copper.

Minimum start-up temperature

- -30 °C (-22 °F).

Maximum operating temperature (power off)

- 60 °C (140 °F).

Maximum operating temperature (power on)

- 60 °C (140 °F).

Nominal voltage

- 120V, 240V.

Bending radius, minimum

- 25 mm (1 in.).

Installation temperature, minimum

- AO, BO: -45 °C (-49 °F).
- BF: -25 °C (-13 °F).

Standards

- IEEE 515, CSA 22.2 130.03.

Certification

- FM CUS 3050047.

Rating

- Wet rated, for outdoor use (WS) (AO, BO).
- PS (2000 kPa/290 psi) (BF).

Warranty

- 1-year basic warranty on the heating cable.
- 10-year limited warranty available.

Application

- Heat tracing of metallic and non-metallic pipes, pumps, vessels and valves, food processing industry, automotive, refrigeration, sprinkler systems, sewage pipes, intake drain pipes, potable water line (BF).

Heating circuit length for ELSR-MA models

Start-up temperature	120V		
	CB capacity (A)	Maximum heating circuit (ft.) for	
		ELSR-MA-3-1-XX	ELSR-MA-5-1-XX
10 °C (50 °F)	10	208	132
	15	233	190
	20	233	190
	25	233	190
0 °C (32 °F)	10	170	110
	15	213	174
	20	213	174
	25	213	174
-10 °C (14 °F)	10	146	94
	15	197	150
	20	197	161
	25	197	161
-30 °C (-22 °F)	10	113	73
	15	172	117
	20	172	141
	25	172	141

Start-up temperature	240V		
	CB capacity (A)	Maximum heating circuit (ft.) for	
		ELSR-MA-3-2-XX	ELSR-MA-5-2-XX
10 °C (50 °F)	10	415	320
	15	415	346
	20	415	346
	25	415	346
0 °C (32 °F)	10	379	273
	15	379	320
	20	379	320
	25	379	320
-10 °C (14 °F)	10	325	239
	15	349	299
	20	349	299
	25	349	299
-30 °C (-22 °F)	10	255	190
	15	307	266
	20	307	266
	25	307	266

ELSR-MA-XX-1-XX output

(on insulated metallic pipes, in accordance with IEEE 515/CSA 22.2 130-03)

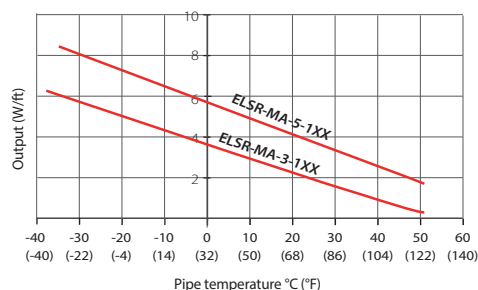

ELSR-MA-XX-2-XX output

(on insulated metallic pipes, in accordance with IEEE 515/CSA 22.2 130-03)

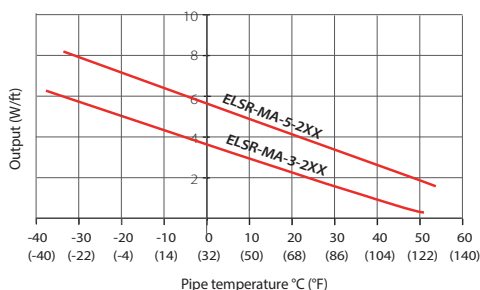

Heating circuit length for ELSR-MA-BF models

Start-up temperature	120V	
	CB capacity (A)	Maximum heating circuit (ft.) for
		ELSR-MA-3-1-BF
10 °C (50 °F)	10	139
	15	167
	20	167
	25	167
0 °C (32 °F)	10	112
	15	153
	20	153
	25	153

Start-up temperature	240V	
	CB capacity (A)	Maximum heating circuit (ft.) for
		ELSR-MA-3-2-BF
10 °C (50 °F)	10	241
	15	302
	20	302
	25	302
0 °C (32 °F)	10	202
	15	282
	20	282
	25	282

ELSR-MA-3-XX-BF (in a filled water pipeline)

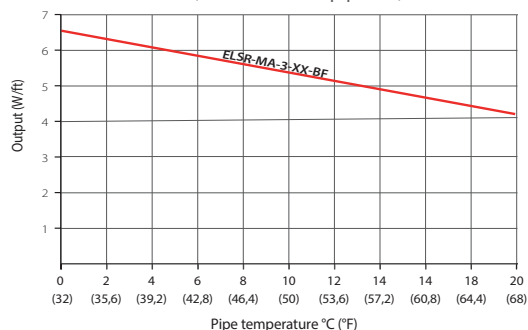

Maximum heating circuit ELSR-MA-XX on the following conditions:

- 120V, 240V
- Voltage drop max. 10%
- MCB type QO (100% utilization)
- Single cable fed 1 end

ELSR-HA

Features

Outer jacket

- Fluoropolymer (BOT).

Bus wire

- Nickel plated copper.

Minimum start-up temperature

- -30 °C (-22 °F).

Maximum operating temperature (power on)

- 120 °C (248 °F).

Maximum operating temperature (power off)

- 150 °C (302 °F), continuous.
- 200 °C (392 °F), power off for 1000 hr cumulative.

Nominal voltage

- 120V, 240V.

Bending radius, min.

- 25 mm (1 in.).

Installation temperature, min.

- -45 °C (-49 °F).

Classification

- II 2G Ex e IIC T3 Gb II 2D Ex tb IIIC.
- T 80 °C Db.
- Class I, Division 2, Groups A, B, C, D.
- Class II, Division 2, Groups E, F, G.
- Class III, T6.
- Class I, Zone 1, AEx / Exe II, T6.
- Class 1, Division 1, Groups B, C, D (Contact manufacturer).

Standards

- CSA C22.2.130.03; -WS.
- CAN/CSA 60079-7:12, 60079-0-11.
- ANSI/IEEE 515, 515.

Certification

- IECEx EPS 12.0006U.
- 12ATEX1431U.
- CSA C US 2547790

Rating

- Wet rated, for outdoor use (WS).

Warranty

- 1-year basic warranty on the heating cable.
- 10-year limited warranty available.

Application

- Freeze protection, heat tracing instrumentation, pipes, vessel and tanks, chemical and petrochemical industries, food processing, automotive.

Heating circuit length for ELSR-HA models

Start-up temperature	120V						240V					
	CB capacity (A)	Maximum heating circuit (ft.) for					CB capacity (A)	Maximum heating circuit (ft.) for				
		ELSR-HA-3-1	ELSR-HA-7-1	ELSR-HA-10-1	ELSR-HA-15-1	ELSR-HA-20-1		ELSR-HA-3-2	ELSR-HA-10-2	ELSR-HA-15-2	ELSR-HA-20-2	
10 °C (50 °F)	10	261	137	113	72	53	10	649	181	115	97	
	15	391	205	169	108	79	15	973	271	173	146	
	20	521	273	225	145	105	20	1267	361	231	194	
	25	559	342	282	181	132	25	1267	452	288	243	
	30	559	411	338	217	158	30	1267	542	346	291	
	35	559	411	374	253	184	35	1267	632	404	340	
0 °C (32 °F)	40	559	411	374	279	200	40	1267	716	461	389	
	10	249	132	108	70	50	10	610	171	110	92	
	15	374	198	162	104	75	15	915	256	165	138	
	20	499	264	216	139	100	20	1220	341	220	184	
	25	559	330	270	174	125	25	1267	427	275	230	
	30	559	396	324	209	150	30	1267	512	330	276	
-10 °C (14 °F)	35	559	411	374	244	175	35	1267	597	385	322	
	40	559	411	374	279	200	40	1267	683	440	368	
	10	239	128	104	67	48	10	576	162	105	87	
	15	358	192	156	101	72	15	864	243	158	131	
	20	477	256	208	134	95	20	1152	324	211	175	
	25	559	320	260	168	119	25	1267	405	263	219	
-30 °C (-22 °F)	30	559	384	312	201	143	30	1267	486	316	262	
	35	559	411	364	235	167	35	1267	567	369	306	
	40	559	411	374	269	191	40	1267	648	421	350	
	10	220	120	97	63	43	10	518	147	97	80	
	15	330	180	145	94	65	15	777	220	145	119	
	20	440	240	193	125	87	20	1036	293	193	159	
-30 °C (-22 °F)	25	550	300	242	157	109	25	1267	367	242	199	
	30	559	360	290	188	130	30	1267	440	290	239	
	35	559	411	338	220	152	35	1267	513	338	278	
	40	559	411	374	251	174	40	1267	587	387	318	

Maximum heating circuit ELSR-HA-XX on the following conditions:

- 120V, 240V
- Voltage drop max. 10%
- MCB type QO (100% utilization)
- Single cable fed 1 end

ELSR-HA-XX-1-BOT output (on insulated metallic pipes)

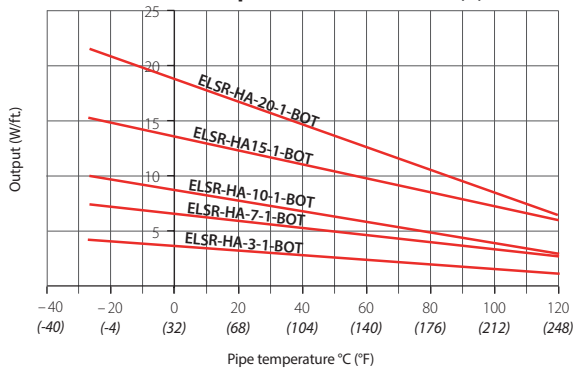

ELSR-HA-XX-2-BOT output (on insulated metallic pipes)

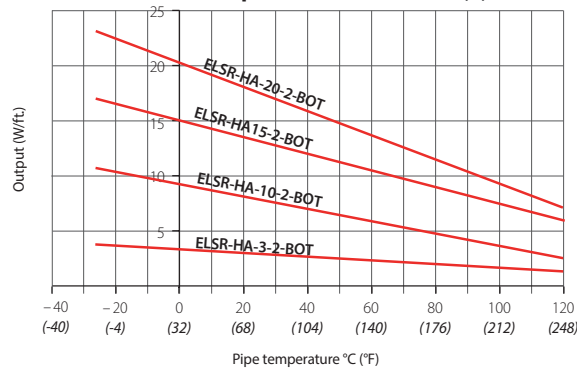

CORRECTION FACTORS/MULTIPLIERS

Correction Factors/Multipliers for operation of heating cables in 208V

To calculate the corrected power output for operation in 208V, multiply the product output at 240V (W/ft.) by the nominal output factor provided for the applicable heating cable type. (See Product sheet at www.ouellet.com).

To calculate maximum heating circuit lengths for operation in 208V (See Cable data sheet of this guide), multiply the published max. heating circuit length at 240V provided for the applicable heating cable type.

Heating Cable Correction Factors/Multipliers	Nominal Output 208V vs. 240V	Heating Circuit Length 208V vs. 240V
ELSR-HA		
ELSR-HA-XX-2	0.74	1.00
ELSR-NA		
ELSR-NA-XX-2	0.88	0.93
ELSR-MA		
ELSR-MA-XX-2	0.82	1.00

Controller options for roof and gutter for de-icing



DS-2C¹: Aerial mounted controller with sensor to detect humidity and temperature, 30A: 100V to 277V, 20A: 28 VDC.



DS-8C¹: Aerial mounted controller with asensor to detect temperature and a sensor to detect humidity with 10 ft. (3 m) cable, 30A, 100V to 277V.



DS-9C¹: Aerial mounted controller with sensor to detect temperature and a sensor to detect humidity with 10 ft. (3 m) cable, 2 x 30A, 100V to 277V.



EX-50: 50 ft. (15 m) extension kit, with connection fittings for humidity sensor.



CDP-2: Interior controller and display for DS products.



ETO2¹: Dual-zone electronic controller, 1-zone: 3 x 16A, 2-zone: 2 x 16A, 120V to 240V.



ETF-744-99: 24V outdoor sensor for measuring temperature.



ETOR-55: Gutter sensor to detect humidity with 33 ft. (10 m) cable.



GPT-130: NEMA 4X IP66 electronic single point line sensing heat trace controller 100-277V, 30A c/w built-in 30 mA GFEP and 20 ft. (6 m) lead, 100k ohms at 25 °C (77 °F) thermistor. Range -40 °C to 110 °C (-40 °F to 230 °F).

¹ Requires a ground fault circuit interrupter (GFCI) in the electrical panel.

Controller options for pipe tracing for use in non-hazardous (ordinary) locations

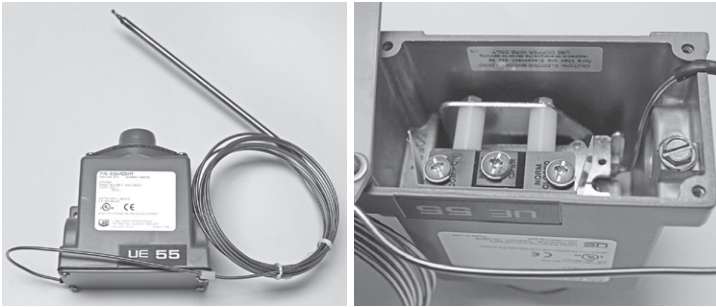

ECA-E55-R25HT¹: SPDT, NEMA 4X thermostat in molded aluminum housing, 22A at 120/250/480V, with 10 ft. (3 m) stainless steel bulb and capillary.

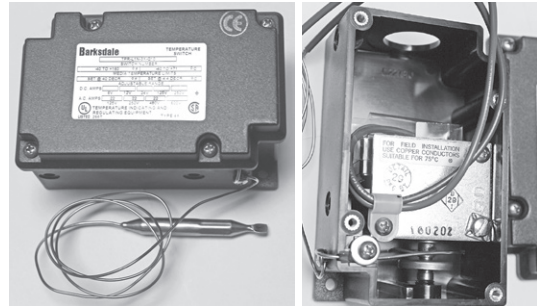

TPR-L1N-3X-Q10¹: SPDT, NEMA 4X thermostat in polycarbonate housing, 22A at 120/250/480V, with 3 ft. (1 m) tinned copper bulb and capillary.

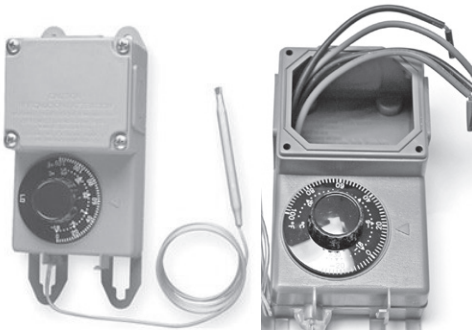

TRF115-005¹: SPDT, NEMA 4X thermostat, range -17 °C to 49 °C (0 °F to 120 °F), 25A at 120/208/240/277V, with 5 ft. (1.5 m) stainless bulb and capillary.

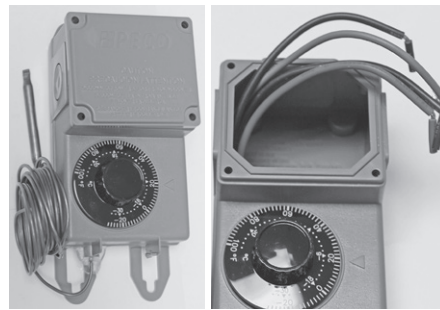

TRF115-007¹: SPDT, NEMA 4X thermostat, range -35 °C to 38 °C (-30 °F to 100 °F), 25A at 120/208/240/277V, with 8 ft. (2.4 m) copper bulb and capillary.



ELTC-14-RTD¹: Digital display wall temperature control with weather proof plastic enclosure. Power relay of 20A at 90-260V. Including 3-wire RTD (Pt-100) sensing element is 5x50 mm with 16.4 ft (5m) of fluoropolymer lead wires, temperature range 0 °C to 250 °C (32 °F to 482 °F).

¹ Requires a ground fault circuit interrupter (GFCI) in the electrical panel.

Controller options for pipe tracing for use in non-hazardous (ordinary) and hazardous locations

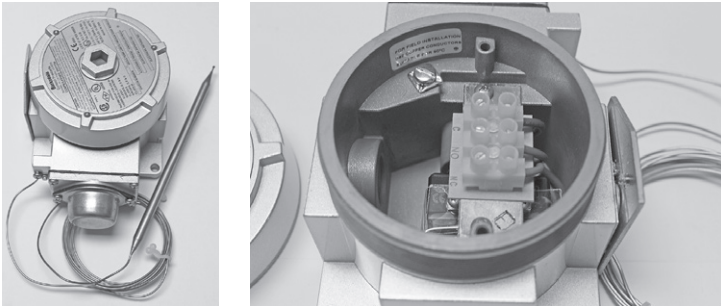

TXR-L2S-10-Q10¹: SPDT, explosion-proof, NEMA 4, 7 and 9 thermostat, in anodized aluminum housing, 22A at 120/250/480V, with 10 ft. (3 m) stainless steel bulb and capillary.

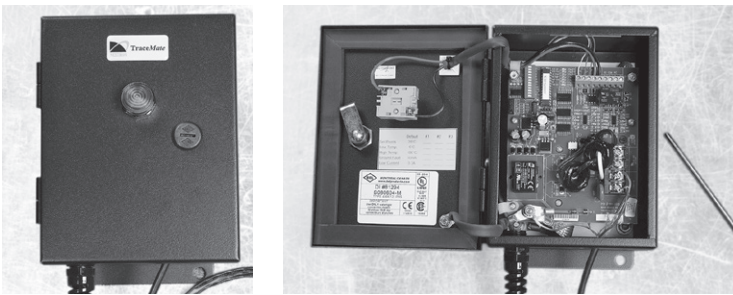

TM-1SIH1-E5-RTD-A1: TraceMate™ I GFCI electronic thermostat for single circuit at 120V, 30A.
TM-1DIH2-E5-RTD-A1: TraceMate™ I GFCI electronic thermostat for single circuit at 240/208V, 30A.
TM-2SIH1-E5-RTD: TraceMate™ II GFCI electronic thermostat for dual circuit at 120V, 30A.
TM-2DIH2-E5-RTD: TraceMate™ II GFCI electronic thermostat for dual circuit at 240/208V, 30A.

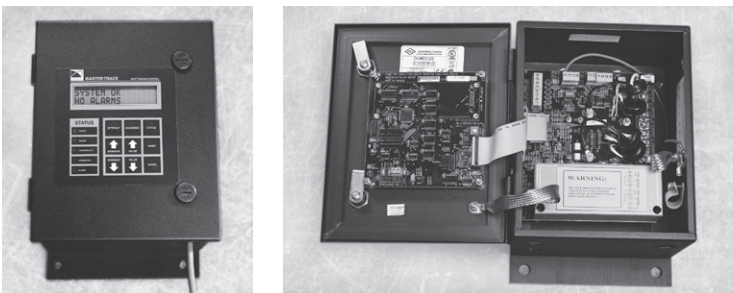

MS-2101²: MasterTrace Single circuit electronic GFCI controller with double pole, 85V to 300V, 30A, with user interface.
MS-2102²: MasterTrace Double circuit electronic GFCI controller with single pole, 120V or 277V, 2 x 30A, with user interface.

¹ Requires a ground fault circuit interrupter (GFCI) in the electrical panel.

² Requires a RTD probe for MasterTrace controller (RTD-7).

INSTALLATION ACCESSORIES AND OPTIONS

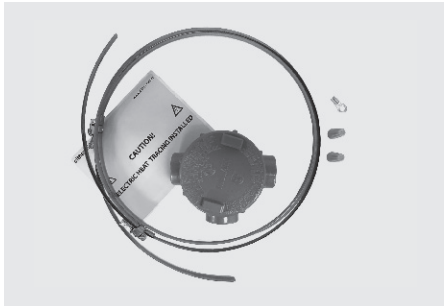

ECA-JB1¹: Junction box for connecting one heating cable to power. It can also be used for splicing two heating cables together. Cold lead (power cord) not included.

This kit includes:

- 1 NEMA 4 junction box
- 2 stainless steel fasteners
- 1 warning label

Power connection kit not included

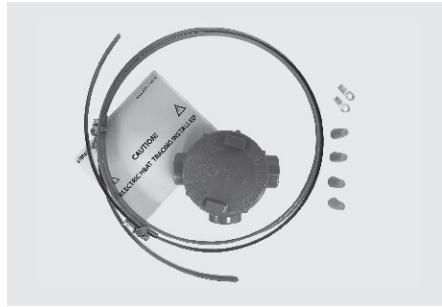

ECA-JB2¹: Junction box for connecting two heating cables to power (cold lead/power cord not included). It can also be used for splicing three heating cables together.

This kit includes:

- 1 NEMA 4 junction box
- 2 Stainless Steel fasteners
- 1 warning labels

Power connection kit not included



ELVB-SRA(x): Power connection kit for connecting one heating cable to power. Termination must be made into CEC approved junction/connection box (junction box not included).

This kit includes:

- 1 ground wire sleeve
- 1 pair of insulation boots
- 1 tube of silicone glue
- 1 installation instructions guide



EL-EC(x): End termination kit for terminating the end of the heating cable.

This kit includes:

- 1 end cap
- 1 tube of silicone glue
- 1 installation instructions guide

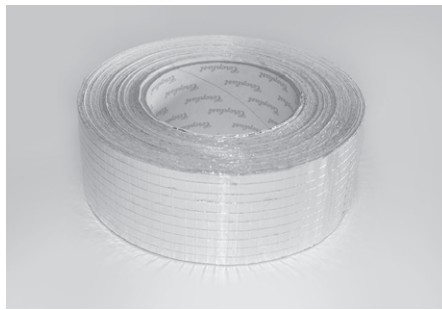

ELB-06C: Self-adhesive aluminum tape for attaching heating cable to pipes, vessels, or gutters.

This item includes:

- 1 self-adhesive aluminum tape, max. temp. = 80 °C (176 °F), 2 in. x 165 ft. (50 mm x 50 m)

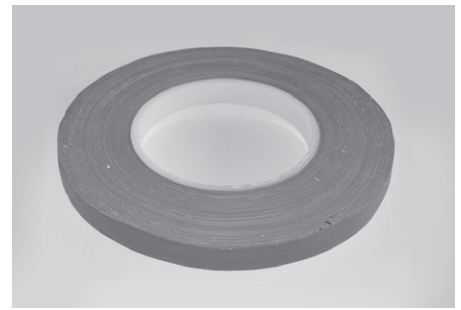

ELB-02B: Self-adhesive glass fiber tape for attaching heating cable to pipes or vessels.

This item includes:

- 1 self-adhesive glass fiber tape, max. temp. = 90 °C (194 °F), 1/2 in. x 165 ft. (12.7 mm x 50 m)

¹ For hazardous location add -EX to part number, contact customers service for pricing.



ELB-20: Stainless steel downspout mounting plate to guide and keep heating cable in place at the entrance of a downspout. The heating cable is secured to the plate using plastic fasteners.

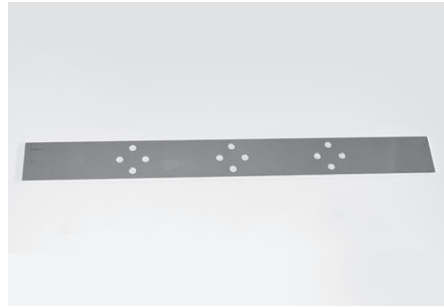

ELB-21: Stainless steel gutter mounting plate to keep heating cable in place inside a gutter. The heating cable is secured to the plate using plastic fasteners.

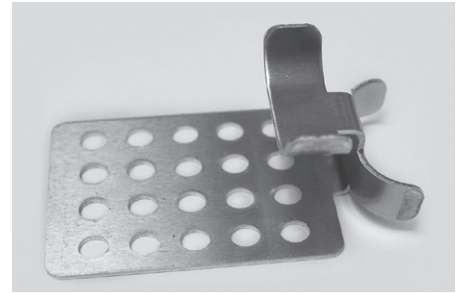

ELB-RCLIP: Roof clips for securing heating cable onto a roof. Screws and waterproofing material are not included.

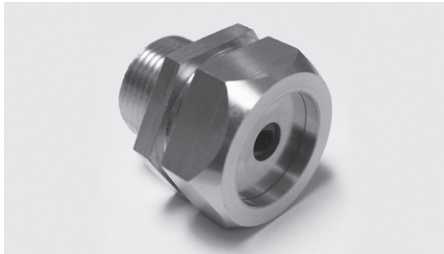

KIT-OSR-ECA-MABF-PH-FIT: Brass gland cable fitting 3/4" NPT non-hazardous location for MA-BF cable.



KIT-OSR-EL-WS03: Bilingual warning label for identifying electrically heat traced pipes and vessels. Label are to be placed on the outside of the insulation covering the pipe or vessel.



KIT-OSR-ELSR-(xx): End and power termination kit with warning sticker.

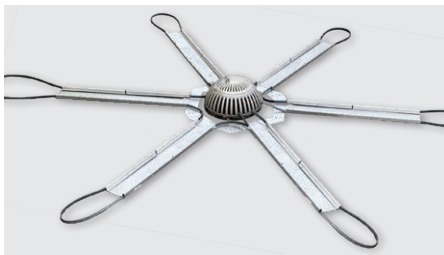

KIT-OSR-DRD-XXXV: Roof drain de-icing kit. With 50' of 120V 7W/ft. OSR-NA cable (ELSR-NA-7-1-BO). With 50' of 240V 8W/ft. OSR-NA cable (ELSR-NA-8-2-BO)



KIT-OSR-MABF-PH-(xx)-CTSOD: Quick connect plumbing kit for 1", 1 1/4" and 1 1/2" OD polyethylene CTS pipes for MA-BF cable.



EL-CLIC-P: Quick connector with supply lead, for 1 to 3 cables for NA cables.



KIT-OSR-MABF-PH-(xx)-ID: Quick connect plumbing kit for 3/4", 1", 1 1/4" and 1 1/2" ID polyethylene pipes for MA-BF cable.



EL-CLIC-S: Quick connector for direct connection or cold lead connection of 1 to 3 cables for NA cables.

COMMERCIAL HEAT TRACING DESIGN FORM

Date: _____ Project Name: _____ Customer Name: _____

Address: _____ Telephone: _____

_____ Email: _____

Install Site

Install Location: Outdoor Indoor

Min. Ambient Temperature: °C °F

Desired Maintain Temperature: °C °F

Wind Speed: km/h MPH

Max. Ambient Temperature: °C °F

Allowable Temperature Tolerance: °C °F

Complete all fields relevant to your application

Piping (Provide drawings if possible)

Pipe Material: _____ in. mm

Pipe Length: _____ in. mm

Insulation Thickness: _____ in. mm

Cladding Installed: Yes No

Pipe Diameter: _____ in. mm

Insulation Type: _____

Cladding Type: _____

Heat Sinks

Type	Size(s)	Quantity of each size
Valve		
Flange/Expansion Joint		
Instrumentation Headers		

Additional Design Considerations (pipe supports, pipe hanger spacing, pipe standoffs, etc.):

Gutters and Downspouts (Provide drawing if possible)

Gutter Material: _____

Gutter Length: _____ ft. m

Quantity of Downspouts: _____

Downspout Lengths total: _____ ft. m

Total Gutter and Downspout Length: _____ ft. m

Notes:

Roofing (Provide drawings if possible)

Roof Type: _____

Roof Material: _____

Desired Spacing of Tracer: _____

Desired Height of Tracer: _____

Notes:

Temperature Control and Monitoring

Is control required? Yes No

If so, what type? _____

Electrical Requirements

Voltage: 120V 208V 240V

Circuit Breaker Capacity (Amps): _____

Prepared by: _____ Company: _____ Date: _____

Sketch Layout if Required



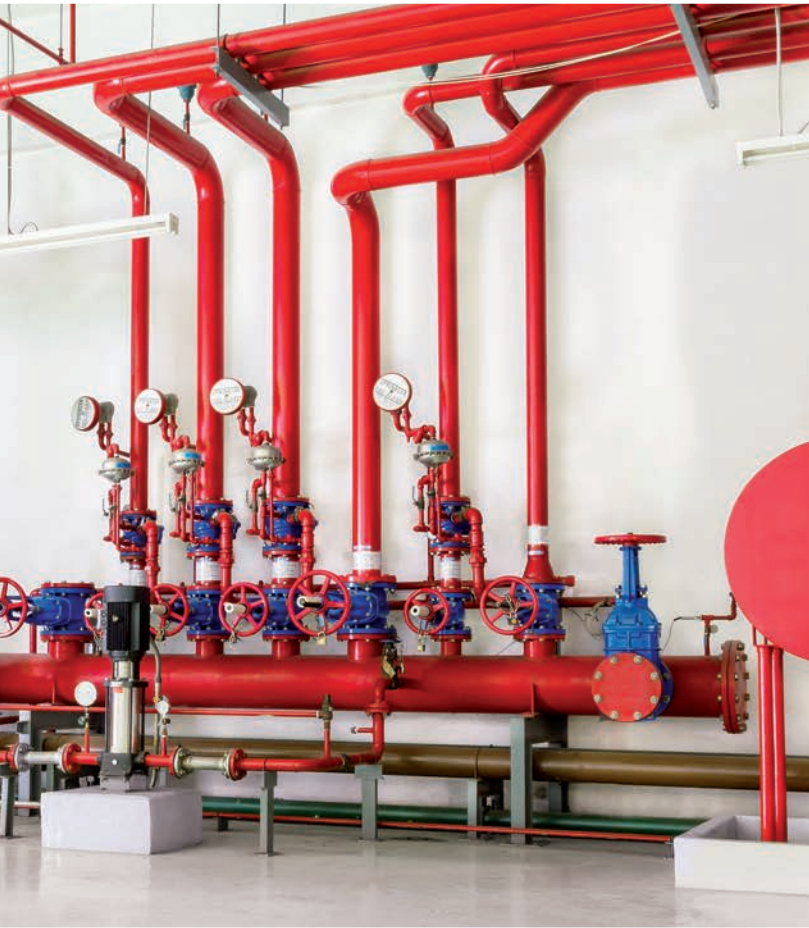

By **INNOVAIR**
SOLUTIONS

1 800 463-7043

info@ouellet.com

ouellet.com



Ouellet Canada Inc. reserves the right to make any changes to this pamphlet or its products at any time without notice.